

Hypertherm®

2019 torch and consumables catalog

For mechanized plasma systems

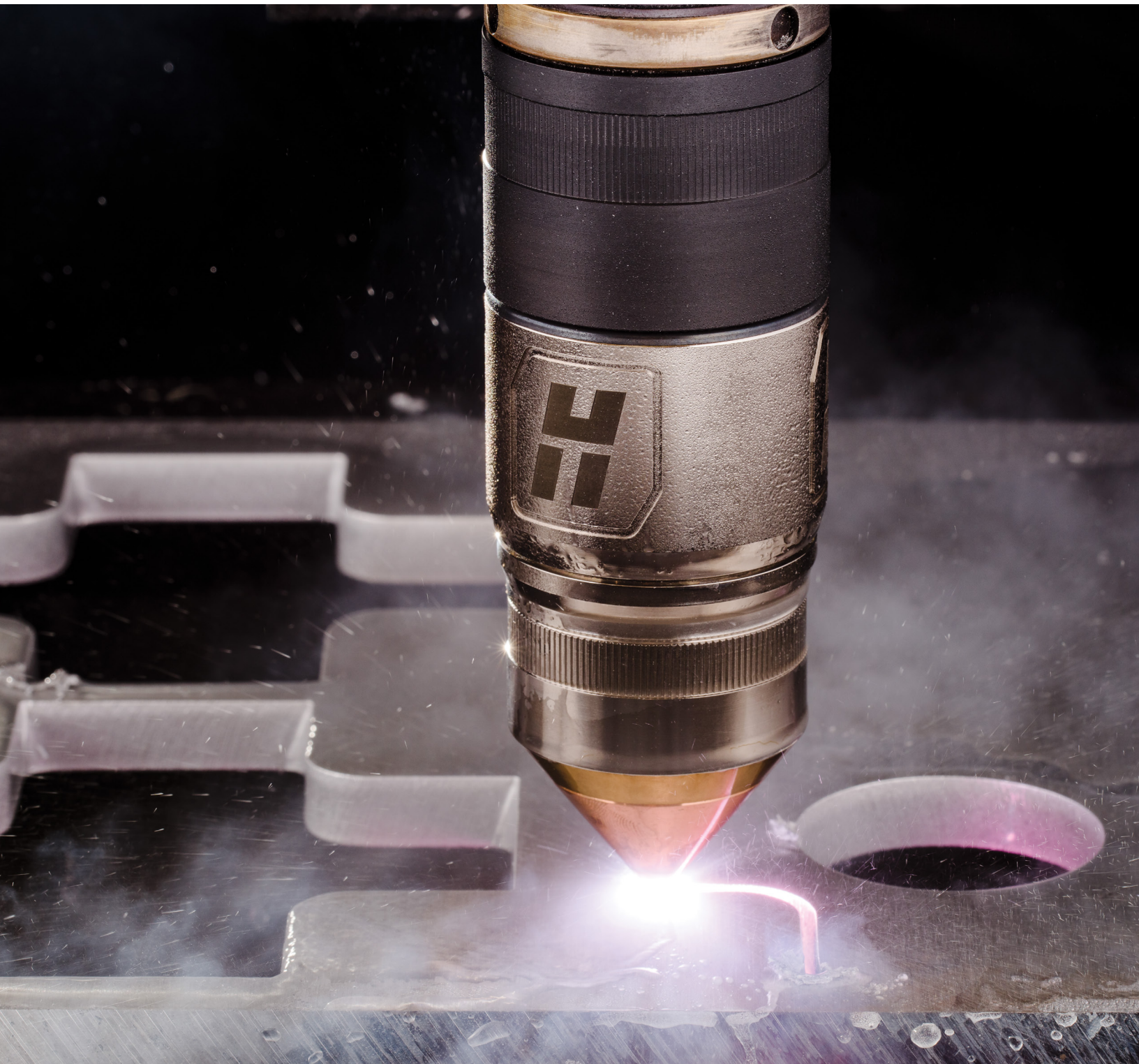



420221
MADE IN USA
IEC 60974-7
55016



Contents

2	Hypertherm technology benefits	40	HSD130®
4	XPR®	40	HSD130 consumables
6	XPR consumables	41	HSD130 torch assembly options
7	XPR torch assembly options	42	HyPerformance® HD4070®
8	HyPerformance® plasma HPRXD®	42	HyPerformance HD4070 consumables
10	HyPerformance HPRXD consumables	43	HyPerformance HD4070 torch assembly options
13	HyPerformance HPRXD torch assembly options	44	HyDefinition® HD4070®
14	MAXPRO200® LongLife® air and oxygen plasma cutting system	44	HyDefinition HD4070 consumables
16	MAXPRO200 consumables – machine	45	HyDefinition HD4070 torch assembly options
17	MAXPRO200 torch assembly options – machine	46	HyPerformance® HD3070®
18	MAXPRO200 consumables – hand	46	HyPerformance HD3070 consumables
19	MAXPRO200 torch assembly options – hand	47	HyPerformance HD3070 torch assembly options
20	SilverPlus® consumables technology	48	HyDefinition® HD3070®
22	HyPerformance® HPR260/130®	48	HyDefinition HD3070 consumables
22	XD technology upgrade kits for HPR260/HPR130	49	HyDefinition HD3070 torch assembly options
24	HyPerformance HPR260/130 consumables	50	HySpeed® HT4400®
25	HyPerformance HPR260/130 torch assembly options	50	HySpeed HT4400 consumables
26	HyPro2000™ upgrade torch for MAX200®	51	HySpeed HT4400 torch assembly options
28	HyPro2000 upgrade consumables for MAX200	52	HT4001®
29	HyPro2000 upgrade torch assembly options for MAX200	52	HT4001 consumables
30	MAX200®	53	HT4001 torch assembly options
30	MAX200 standard consumables – machine torch	54	HT4000®
31	MAX200 standard torch assembly options – machine	54	HT4000 consumables and torch assembly options
32	MAX200 consumables – PAC200 T/E hand torch	55	HT400®
33	MAX200 torch assembly options – PAC200 T/E hand	55	HT400 consumables and torch assembly options
34	HyPro2000™ upgrade torch for HT2000®	56	PAC500™
36	HyPro2000 upgrade consumables for HT2000	56	PAC500 consumables and torch assembly options
37	HyPro2000 upgrade torch assembly options for HT2000		Reference
38	HT2000®	57	Additional mirror-image cutting (CCW) consumables available
38	HT2000 standard and HySpeed consumables	58	Value of preventive maintenance and proper torch and consumable use
39	HT2000 torch assembly options	60	Preventive Maintenance kits

Current

Legacy

Throughout the catalog, red and grey bars are used to distinguish current from legacy systems.

Hypertherm technology benefits

Hypertherm designs consumables to achieve fast cutting speeds, long life, and superior cut quality for high productivity and low operating costs.

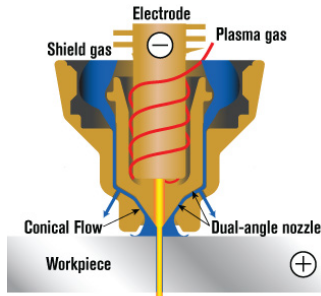

Conical Flow

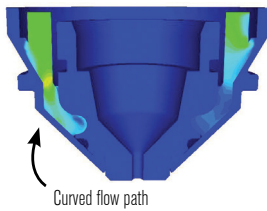

CoolFlow

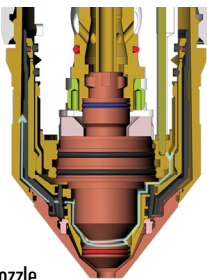

Cool nozzle

Advanced axial swirl ring allows the long vented nozzle with exposed vent holes and swirl ring to align near the tip of the electrode, ensuring the correct amount of gas flow and optimal consumable life.

Chambered swirl ring gradually reduces gas pressure at the end of the cut to stabilize the hafnium insert prior to arc termination; this extends nozzle and electrode life.

Coaxial-assist™ jet increases cutting speed and cut quality by extending the tip of the nozzle into the exit of the shield.

Conical Flow™ nozzle technology increases arc energy density for superior cut quality with little dross.

CoolCore® allows for improved cooling of the electrode through effective removal of heat from the hafnium.

CoolFlow™ delivers enhanced cooling of the nozzle through key features such as a deep groove, angled o-ring seal and specific shoulder contact for increased nozzle life and cut quality.

Cool nozzle feature on the on the XPR™ 300-amp oxygen process provides liquid cooling directly to the nozzle bore. This cooling is a significant factor in increasing cut quality over the life of the consumables by over 40%.

Dimpled electrode extends electrode life by preventing material from blowing on the nozzle when first ignited.

HDi® technology delivers HyDefinition® quality to thin stainless steel cutting from 3 mm (12 ga.) to 6 mm (1/4").

HyLife® extends electrode life and lowers operating costs.

HySpeed® technology utilizes Coaxial-assist jet technology to boost cutting speeds as much as 50% over conventional designs.

LongLife® ramps current and gas flow up and down in a tightly controlled manner to reduce electrode and nozzle erosion.

Plasma dampening delivers increased arc density and cut speeds on thin stainless while maintaining arc stability and smoother cut edges.

PowerPierce® liquid cooled shield technology repels molten metal during piercing. Enables robust production pierce capability up to 50 mm (2") mild steel and 75 mm (3") stainless steel and aluminum. Delivers speed and thickness capabilities.

300 pierces at 50 mm (2")

41 pierces at 45 mm (1-3/4")

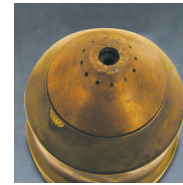

HPR400XD with PowerPierce technology

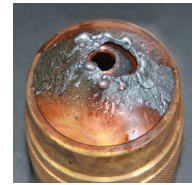

Competitor A without PowerPierce technology

Quick-disconnect torch allows for ease of mounting and changing of the torch.

QuickLock™ electrode delivers easy 1/4 turn tightening, reducing job setup time.

SilverPlus® silver front end tip which dramatically extends electrode life, reduces the number of change outs and significantly reduces operating cost.

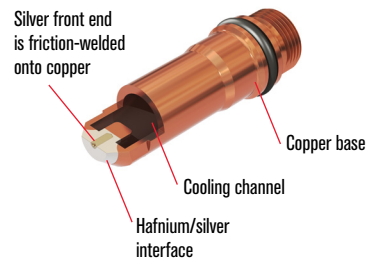

TrueFlow™ allows for centered electrode alignment with the water tube to ensure optimal cooling, which increases life and produces a higher and consistent cut quality.

Vent-to-shield technology mixes hydrogen reclaimed from the vented plasma gas with the shield gas to reduce angularity and deliver more consistent edge color on stainless steel up to 12 mm (1/2").



QuickLock electrode

Vented shield is electrically isolated to prevent double arcing, the vent holes around the orifice stabilize the arc, cool the consumables, and protect them from spatter. These features improve piercing capabilities and increase consumable life.

Vented Water Injection™ (VWI) process features a vented N₂ plasma and an H₂O shield. Edges are square, angularity is reduced and surface finish is excellent on non-ferrous materials, especially aluminum.

Swirl ring

The main function of the swirl ring is to control the swirling action of the plasma gas flow around the electrode in order to center the cutting arc on the electrode and through the nozzle, and to constrict the cutting arc for faster cut speeds and thicker cut capability.

Shield cap

The outer retaining cap holds the shield in place over the nozzle (or inner retaining cap, if applicable) and directs secondary gas or shield gas to the shield.

Nozzle cap

The inner retaining cap's primary function is to hold the nozzle and swirl ring in place while directing coolant flow to the exterior of the nozzle.

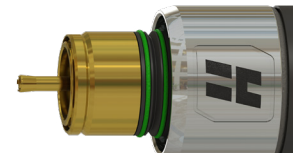
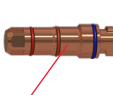
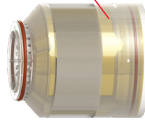

Shield

The main function of the shield is to protect and cool the other consumables, especially the nozzle from molten splatter. In some cases, the shield also contributes to the swirling action of the plasma gas.

Nozzle

The primary function of the nozzle is to shape, direct, and constrict the plasma arc.

Electrode

The primary function of the electrode is to provide power to the plasma arc. It is the starting point and electrical contact point of the plasma arc.

Water tube

The water tube is crucial for effective electrode cooling.

Systems	Breakthrough plasma technologies							HyPerformance® plasma							LongLife® air and oxygen plasma				Air plasma																
	X-Definition™ cut quality	Vented Water Injection™	Arc response technologies™	3 Plasma gas mixing for non ferrous	Cool nozzle	50 degree True Bevel™	Argon-assist	WiFi	Lowest operating cost	True Hole® technology	True Bevel™ technology	Patented PowerPierce® technology for extreme piercing capability	HDI® thin stainless technology	Remote (CNC) gas switching capability	More process options for optimizing cut quality	Highest cut speeds	Mark, cut, and bevel with same consumables	HyDefinition® technology	Can be used on the largest machine frames	100% duty cycle	Quick-disconnect torch	Thicker cutting capability	Oxygen and multi-gas capability for improved cut quality, faster cut speeds, and improved weldability	Lower operating cost	Serial communications enable full control from the CNC	Bevel capability up to 45°	Automatic gas technology minimizes operator intervention	Built and tested to withstand the harshest conditions	Good weldability	Fast cut speeds per recommended thickness	Good cut quality	Low operating cost			
XPR™	●	●	●	●	●	●	●	●	●	●	●	●	●	●	●	●	●	●	●	●	●	●	●	●	●	●	●	●	●	●	●	●	●		
HPRXD®									●	●	●	●	●	●	●	●	●	●	●	●	●	●	●	●	●	●	●	●	●	●	●	●	●	●	
MAXPRO200®																			●	●	●	●	●	●	●	●	●	●	●	●	●	●	●	●	
Powermax®																									●	●	●	●	●	●	●	●	●	●	●



The most significant advance in mechanized plasma cutting technology redefines what plasma can do.

Industry leading cut quality – X-Definition

The XPR advances HyDefinition® cut quality by blending new technology with refined processes for next generation, X-Definition™ cutting on mild steel, stainless steel and aluminum.

- Consistent ISO range 2 results on thin mild steel and extended range 3 cut quality on thicker mild steel and stainless steel
- Superior results on aluminum using Vented Water Injection™ (VWI)



Optimized productivity and reduced operating costs

- Operating costs reduced by over 50%
- Up to 15% higher cut speeds on thicker materials
- Consumable life increases of over 40%
- 20% thicker piercing on stainless steel and 30% thicker on mild steel

Engineered system optimization and ease of use

- Increases consumable life 3 times that of competitor's systems by eliminating the impact of ramp down errors
- Reduces the impact of catastrophic electrode blowouts which can damage the torch at high current levels
- Automatic system monitoring and specific troubleshooting codes for improved maintenance and service prompts
- EasyConnect™ torch lead and one hand torch-to receptacle connection for fast and easy change-outs
- QuickLock™ electrode for easy consumable replacement
- WiFi in the power supply can connect to mobile devices and LAN for multiple system monitoring and service



Process control and delivery

Three GasConnect console options offer unmatched mild steel cut quality with each console delivering successively enhanced cutting capabilities on stainless steel and aluminum. All consoles can be fully controlled through the CNC for high productivity and ease of use.



Core™ console



Vented Water Injection™ (VWI) console



OptiMix™ console

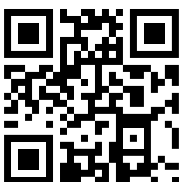

Technologies

Chambered swirl ring	gradually reduces gas pressure at the end of the cut to stabilize the hafnium insert prior to arc termination; this extends nozzle and electrode life.
Conical Flow™	nozzle technology increases arc energy density for superior cut quality with little dross.
CoolFlow™	delivers enhanced cooling of the nozzle through key features such as a deep groove, angled o-ring seal and specific shoulder contact for increased nozzle life and cut quality.
Cool nozzle	feature on the 300-amp oxygen process provides liquid cooling directly to the nozzle bore. This cooling is a significant factor in increasing cut quality over the life of the consumables by over 40%.
HyDefinition®	vented nozzle technology aligns and focuses the plasma arc for powerful precision cutting, superior quality, and consistency.
LongLife®	ramps current and gas flow up and down in a tightly controlled manner to reduce electrode and nozzle erosion.
PowerPierce®	liquid cooled shield technology repels molten metal during piercing. Enables robust production pierce capability up to 50 mm (2") mild steel and 75 mm (3") stainless steel and aluminum. Delivers speed and thickness capabilities.
Plasma dampening	delivers increased arc density and cut speeds on thin stainless while maintaining arc stability and smoother cut edges.
QuickLock™ electrode	delivers easy 1/4 turn tightening, reducing job setup time.



TrueFlow™	allows for centered electrode alignment with the water tube to ensure optimal cooling, which increases life and produces a higher and consistent cut quality.
Vented shield	is electrically isolated to prevent double arcing, the vent holes around the orifice stabilize the arc, cool the consumables, and protect them from spatter. These features improve piercing capabilities and increase consumable life.
Vent-to-shield	technology mixes hydrogen reclaimed from the vented plasma gas with the shield gas to reduce angularity and deliver more consistent edge color on stainless steel up to 12 mm (1/2").
Vented Water Injection™ (VWI)	process features a vented N ₂ plasma and an H ₂ O shield. Edges are square, angularity is reduced and surface finish is excellent on non-ferrous materials, especially aluminum.

XPR™ consumables



Technologies

Chambered swirl ring

Conical Flow™

CoolFlow™

Cool nozzle

HyDefinition®

LongLife®

PowerPierce®

Plasma dampening

QuickLock™ electrode

TrueFlow™

Vented shield

Vent-to-shield

VWI™

Mild steel consumables

XPR		Amperage	Process	Shield cap	Shield	Nozzle retaining cap	Nozzle	Swirl ring	Electrode	Water tube
170	300									
●	●	30 A	O ₂ /O ₂	420200	420228	420365	420225	420407	420222	420368
●	●	50 A	O ₂ /Air	420200	420237	420365	420234	420233	420231	420368
●	●	80 A	O ₂ /Air	420200	420246	420365	420243	420242	420240	420368
●	●	130 A	O ₂ /Air	420200	420255	420365	420252	420242	420249	420368
●	●	170 A	O ₂ /Air	420200	420513	420365	420261	420260	420258	420368
	●	300 A	O ₂ /Air	420200	420491	420365	420279	420406	420276	420368



Non-ferrous by amp

●	●	40 A	N ₂ /N ₂	420200	420291	420365	420288	420314	420303	420368
			Air/Air	420200	420291	420365	420288	420314	420294	420368
●	●	60 A	N ₂ /N ₂	420200	420309	420365	420297	420323	420303	420368
			F5/N ₂	420200	420309	420365	420297	420323	420303	420368
		80 A	N ₂ /H ₂ O	420200	420300	420365	420296	420323	420303	420368
			Air/Air	420200	420309	420365	420297	420323	420294	420368
●	●	80 A	N ₂ /N ₂	420200	420309	420365	420306	420323	420303	420368
			F5/N ₂	420200	420309	420365	420306	420323	420303	420368
			N ₂ /H ₂ O	420200	420300	420365	420290	420323	420303	420368
			Air/Air	420200	420309	420365	420306	420323	420294	420368
●	●	130 A	N ₂ /N ₂	420200	420318	420365	420315	420314	420356	420368
			H ₂ -Ar-N ₂ /N ₂	420200	420318	420365	420315	420323	420356	420368
			N ₂ /H ₂ O	420200	420469	420365	420315	420314	420356	420368
●	●	170 A	N ₂ /N ₂	420200	420327	420365	420324	420314	420356	420368
			H ₂ -Ar-N ₂ /N ₂	420200	420327	420365	420324	420323	420356	420368
			N ₂ /H ₂ O	420200	420472	420365	420324	420314	420356	420368
			Air/Air	420200	420513	420365	420524	420260	420258	420368
	●	300 A	N ₂ /N ₂	420200	420362	420365	420359	420323	420356	420368
			H ₂ -Ar-N ₂ /N ₂	420200	420362	420365	420359	420358	420356	420368
			N ₂ /H ₂ O	420200	420475	420365	420359	420323	420356	420368

Non-ferrous by process

●	●	N ₂ /N ₂	40 A	420200	420291	420365	420288	420314	420303	420368
●	●		60 A	420200	420309	420365	420297	420323	420303	420368
●	●		80 A	420200	420309	420365	420306	420323	420303	420368
●	●		130 A	420200	420318	420365	420315	420314	420356	420368
●	●		170 A	420200	420327	420365	420324	420314	420356	420368
	●		300 A	420200	420362	420365	420359	420323	420356	420368
●	●	F5/N ₂	60 A	420200	420309	420365	420297	420323	420303	420368
●	●		80 A	420200	420309	420365	420306	420323	420303	420368
●	●	Air/Air	40 A	420200	420291	420365	420288	420314	420294	420368
●	●		60 A	420200	420309	420365	420297	420323	420294	420368
●	●		80 A	420200	420309	420365	420306	420323	420294	420368
●	●		170 A	420200	420513	420365	420524	420260	420258	420368
●	●	N ₂ /H ₂ O	60 A	420200	420300	420365	420296	420323	420303	420368
●	●		80 A	420200	420300	420365	420290	420323	420303	420368
●	●		130 A	420200	420469	420365	420315	420314	420356	420368
●	●		170 A	420200	420472	420365	420324	420314	420356	420368
●	●		300 A	420200	420475	420365	420359	420323	420356	420368
●	●	H ₂ -Ar-N ₂ /N ₂	130 A	420200	420318	420365	420315	420323	420356	420368
●	●		170 A	420200	420327	420365	420324	420323	420356	420368
●	●		300 A	420200	420362	420365	420359	420358	420356	420368



Please refer to page 57 for mirror-image cutting consumables.

XPR™ torch assembly options



Torch assembly options

	Part number Standard	Part number Standard Bevel/Robotic	Part number Bevel/Robotic	Description
	428383	428825	428831*	Lead: 2 m (6.6')
	428384	428826	428832*	Lead: 2.5 m (8.2')
	428385	428827	428833*	Lead: 3 m (9.8')
	428386	428828	428834*	Lead: 3.5 m (11.5')
	428824	428829	428835*	Lead: 4 m (13.1')
	428387	428830	428836*	Lead: 4.5 m (14.8')
		428916		Lead: Thru arm robotic 3.5 m (11.5')
		428918		Lead: Thru arm robotic 4.5 m (14.8')
1	420500			Torch mounting sleeve: Standard
	420501			Torch mounting sleeve: Short
	420502			Torch mounting sleeve: Extended
5		420788		Rotational torch mounting sleeve: Short
		420789		Rotational torch mounting sleeve: Medium
		420790		Rotational torch mounting sleeve: Extended
2	420220			Quick-disconnect torch receptacle
3	420221			Quick-disconnect XPR torch
4	420368			Water tube
	428488			Torch assembly, 300 A mild steel consumables
	428846			Torch assembly, 170 A mild steel consumables

*Bevel/Robotic lead sets 428831–428836 include an extended 1.2 m (48") strain relief.

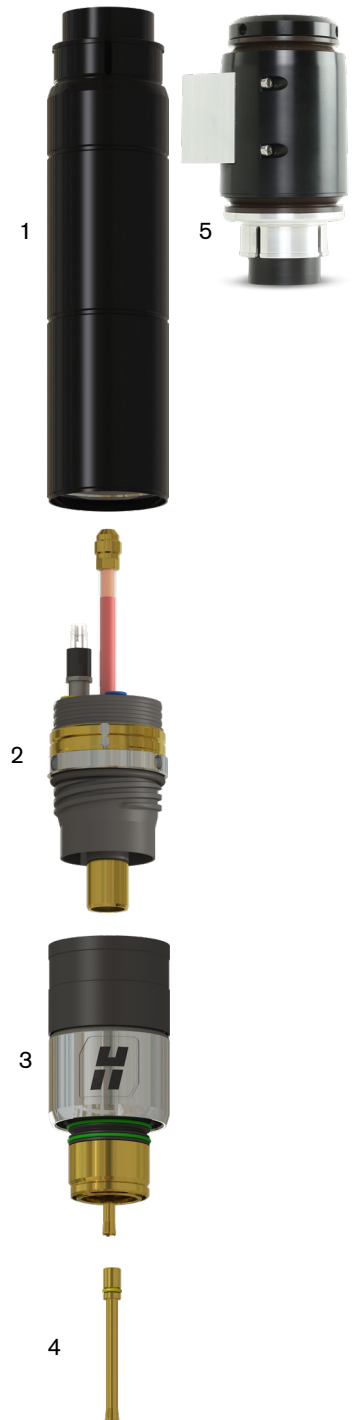

Additional parts available (not shown)

Part number	Description
429013	XPR electrode torque tool
428842	XPR170 mild steel consumables starter kit (torch included)
428841	XPR170 non-ferrous consumables starter kit (torch included)
428840	XPR170 mild steel consumables starter kit
428843	XPR170 non-ferrous consumables starter kit
428878	XPR170 electronics preventive maintenance kit (200–240 V)
428879	XPR170 electronics preventive maintenance kit (380–600 V)
810060	XPR170 plasma instruction manual
028872	Torch coolant – Cool solution: 70/30 PG, 1-gal.
809490	XPR Preventive maintenance instruction manual
104119	Consumables removal tool
027055	Silicone lubricant for o-rings
428618	XPR300 Mild steel consumables starter kit (torch included)
428619	XPR300 Stainless steel consumables starter kit (torch included)
428616	XPR300 Mild steel consumables starter kit
428944	XPR170 Core console non-ferrous consumables starter kit
428945	XPR300 Core console non-ferrous consumables starter kit
428617	XPR300 Stainless steel consumables starter kit
428639	Torch rebuild and filter without coolant preventive maintenance kit
428640	Torch rebuild and filter with coolant preventive maintenance kit
428641	XPR300 Electronics preventive maintenance kit (200–240 V)
428642	XPR300 Electronics preventive maintenance kit (380–600 V)
809480	XPR300 plasma instruction manual

See page 58 to learn about the value of preventive maintenance.

HyPerformance® plasma HPRXD®



HyPerformance plasma systems deliver HyDefinition® cut quality at a fraction of the operating costs.

By incorporating Hypertherm's proven HyDefinition, LongLife®, PowerPierce®, HDi® and True Hole® technologies, HyPerformance plasma boosts overall performance, productivity and profitability. The systems offer unmatched process flexibility to cut, bevel and mark metals, including 3D shapes, up to 160 mm (6-1/4") thick.





Technologies

Advanced Axial Swirl Ring	allows the long vented nozzle with exposed vent holes and swirl ring to align near the tip of the electrode, ensuring the correct amount of gas flow and optimal consumable life.
Chambered Swirl Ring	gradually reduces gas pressure at the end of the cut to stabilize the hafnium insert prior to arc termination; this extends nozzle and electrode life.
Conical Flow™	nozzle technology increases arc energy density for superior cut quality with little dross.
CoolCore®	allows for improved cooling of the electrode through effective removal of heat from the hafnium.
CoolFlow™	delivers enhanced cooling of the nozzle through key features such as a deep groove, angled o-ring seal and specific shoulder contact for increased nozzle life and cut quality.
HDi®	delivers HyDefinition® quality to thin stainless steel cutting from 3 mm (12 ga.) to 6 mm (1/4").
HyDefinition®	vented nozzle technology aligns and focuses the plasma arc for powerful precision cutting, superior quality, and consistency.
HyLife®	extends electrode life and lowers operating costs.
LongLife®	ramps current and gas flow up and down in a tightly controlled manner to reduce electrode and nozzle erosion.
PowerPierce®	liquid cooled shield technology repels molten metal during piercing. Enables robust production pierce capability up to 50 mm (2") mild steel and 75 mm (3") stainless steel and aluminum. Delivers speed and thickness capabilities.
SilverPlus®	silver front end tip which dramatically extends electrode and nozzle life, reduces the number of change outs and significantly reduces operating cost. For more information on SilverPlus technology, see page 21.

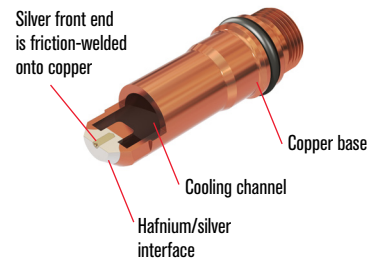

TrueFlow™	allows for centered electrode alignment with the water tube to ensure optimal cooling, which increases life and produces a higher and consistent cut quality.
Vented Shield	is electrically isolated to prevent double arcing, the vent holes around the orifice stabilize the arc, cool the consumables, and protect them from spatter. These features improve piercing capabilities and increase consumable life.

HyPerformance® HPR800/400/260/130XD® consumables

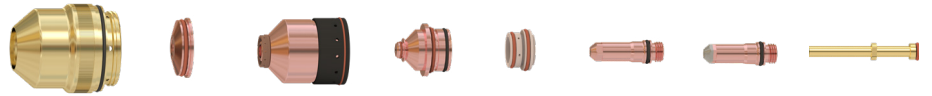

Technologies

Mild steel consumables

Advanced Axial Swirl Ring

Chambered Swirl Ring

Conical Flow™

CoolCore®

CoolFlow™

HyDefinition®

HyLife®

LongLife®

PowerPierce®

SilverPlus®

TrueFlow™

Vented Shield

HDi®

	HPR XD				Amperage	Shield cap	Shield	Nozzle retaining cap	Nozzle	Swirl ring	Electrode	SilverPlus electrode	Water tube
	800	400	260	130									
	●	●	●	●	30 A	220747	220194	220754	220193	220180	220192	----	220340
	●	●	●	●	50 A	220747	220555	220754	220554	220553	220552	----	220340
	●	●	●	●	80 A	220747	220189	220756	220188	220179	220187	420566	220340
	●	●	●	●	130 A	220747	220183	220756	220182	220179	220181	220665	220340
	●	●	●		200 A	220637	220761	220757	220354	220353	220352	220666	220340
	●	●	●		260 A	220637	220764	220760	220439	220436	220435	220668	220340
	●	●			400 A	220637	220636	220635	220632	220631	220629	420530	220571
	●	●	●	●	80 A Bevel	220637	220742	220845	220806	220179	220802	----	220700
	●	●	●	●	130 A Bevel	220637	220742	220740	220646	220179	220649	----	220700
	●	●	●		200 A Bevel	220637	220658	220845	220659	220353	220662	----	220700
	●	●	●		260 A Bevel	220637	220741	220740	220542	220436	220541	----	220571
	●	●	●		260 A* Bevel	220637	220897	220896	220898	220436	220899	----	220571
	●	●			400 A Bevel	220637	220636	220635	220632	220631	220629	----	220571

* Recommended for use if you have excessive slag, or the torch is misfiring, when using standard bevel consumables.



Please refer to page 57 for mirror-image cutting consumables.

HyPerformance® HPR800/400/260/130XD® consumables



Stainless steel consumables

HPR XD				Amperage	Shield cap	Shield	Nozzle retaining cap	Nozzle	Swirl ring	Electrode	Water tube
800	400	260	130								
●	●	●	●	45 A	220747	220202	220755	220201	220180	220308	220340
●	●	●	●	60 A HDi	220747	220815	220814	220847	220180	220339	220340
●	●	●	●	80 A	220747	220338	220755	220337	220179	220339	220340
●	●	●	●	130 A	220747	220198	220755 (H35)	220197	220179	220307	220340
●	●	●	●				220756 (N ₂)				
●	●	●		200 A	220637	220762	220758	220343	220342	220307	220340
●	●	●		260 A	220637	220763	220758	220406	220405	220307	220340
●	●			400 A	220637	220707	220712	220708	220405	220709	220571
●				600 A	220637	220707	220635 (H35)	220859	220353 (H35)	220709	220571
●							220885 (N ₂)		220405 (N ₂)		
●				800 A ≤100 mm (4")	220637	220886	220885	220884	220353	220882	220881
●				800 A >100 mm (4")	220637	220886	220712	220884	220350	220882	220881
●	●	●	●	130 A Bevel	220637	220738	220739	220656	220179	220606	220571
●	●	●		260 A Bevel	220637	220738	220739	220607	220405	220606	220571
●	●			400 A Bevel	220637	220707	220712	220708	220405	220709	220571
●				600 A	220637	220707	220635 (H35)	220859	220353 (H35)	220709	220571
●							220885 (N ₂)		220405 (N ₂)		
●				800 A Bevel ≤100 mm (4")	220637	220886	220885	220884	220353	220882	220881
●				800 A Bevel >100 mm (4")	220637	220886	220712	220884	220350	220882	220881

Please refer to page 57 for mirror-image cutting consumables.

HyPerformance® HPR800/400/260/130XD® consumables



Technologies

Aluminum consumables

Advanced Axial Swirl Ring

Chambered Swirl Ring

Conical Flow™

CoolCore®

CoolFlow™

HyDefinition®

HyLife®

LongLife®

PowerPierce®

SilverPlus®

TrueFlow™

Vented Shield

HDi®

	HPR XD				Amperage	Shield cap	Shield	Nozzle retaining cap	Nozzle	Swirl ring	Electrode	Water tube
	800	400	260	130								
Advanced Axial Swirl Ring	●	●	●	●	45 A	220747	220202	220756	220201	220180	220308	220340
Chambered Swirl Ring	●	●	●	●	130 A	220747	220198	220755 (H35)	220197	220179	220307 (H35)	220340
Conical Flow™	●	●	●	●				220756 (Air)			220181 (Air)	
CoolCore®	●	●	●	●								
CoolFlow™	●	●	●		200 A	220637	220762	220759	220346	220342	220307	220340
HyDefinition®	●	●	●		260 A	220637	220763	220758	220406	220405	220307	220340
HyLife®	●	●			400 A	220637	220707	220712	220708	220405	220709	220571
LongLife®	●				600 A	220637	220707	220712 (H35)	220859	220353 (H35)	220709	220571
PowerPierce®	●							220885 (N ₂)		220405 (N ₂)		
SilverPlus®	●				800 A ≤100 mm (4")	220637	220886	220885	220884	220353	220882	220881
TrueFlow™	●				800 A >100 mm (4")	220637	220886	220712	220884	220350	220882	220881
Vented Shield												
HDi®												



Please refer to page 57 for mirror-image cutting consumables.

HyPerformance® HPR800/400/260/130XD® torch assembly options

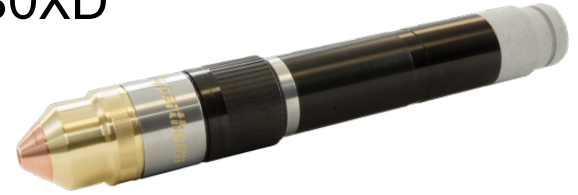

Standard leads

1	Part number		Lead length
	6' gas	8' gas	
	228291	228410	2 m (6')
	228292	228411	3 m (10')
	228293	228412	4.5 m (15')
	228294	228413	6 m (20')
	228295	228414	7.5 m (25')
	228296	228415	10 m (35')
	228297	228416	15 m (50')
	228547	228516	20 m (65')

Robotic/Bevel leads

1	Part number		Lead length
	6' gas	8' gas	
	228514	228516	2 m (6')
	228515	228517	2.4 m (8')
	228475	228482	3 m (10')
	228476	228483	3.6 m (12')
	228477	228484	4.5 m (15')
	228478	228485	6 m (20')
	228479	228486	7.5 m (25')
	228480	228487	10 m (35')
	228481	228488	15 m (50')

Mounting sleeves

2	Part number	Description	Length	Diameter
	220789	Standard	178 mm (7")	50.8 mm (2")
	220788	Short	114 mm (4.5")	50.8 mm (2")
	220790	Extended	248 mm (9.75")	50.8 mm (2")
	220864	Rotational	146 mm (5.5")	50.8 mm (2")

Quick-disconnect receptacle

3	Part number
	220705

HyPerformance HPRXD torch main body

4	Part number
	220706

Additional parts available (not shown)

Part number	Description
104119	Consumables removal tool
027055	Silicone lubricant for o-rings
420383	Short torch w/leads
128879	Torch rebuild kit
128880	Quick-disconnect kit, o-ring and connector
228603	HPR800XD Stainless steel/Aluminum consumables starter kit
228367	HPR400XD Mild steel consumables starter kit
228368	HPR400XD Stainless steel/Aluminum consumables starter kit
228422	HPR260XD Mild steel consumables starter kit
228423	HPR260XD Stainless steel/Aluminum consumables starter kit
428627	HPR260XD Mild steel bevel consumables starter kit
228420	HPR130XD Mild steel consumables starter kit
228421	HPR130XD Stainless steel/Aluminum consumables starter kit
428626	HPR130XD Mild steel bevel consumables starter kit
028872	Torch coolant – Cool solution: 70/30 PG, 1-gal.
806330	HPR130XD Auto gas instruction manual
806320	HPR130XD Manual gas instruction manual
806350	HPR260XD Auto gas instruction manual
806340	HPR260XD Manual gas instruction manual
806160	HPR400XD Auto gas instruction manual
806170	HPR400XD Manual gas instruction manual
806500	HPR800XD Auto gas instruction manual
806490	HPR800XD Manual gas instruction manual

See page 58 to learn about the value of preventive maintenance.

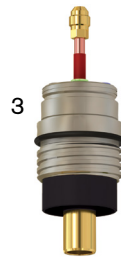

Additional torches available

Part number	800 A	400 A	260 A	130 A	Standard consumables	Bevel consumables	Standard sleeve	Short sleeve	Extended sleeve	Robotic sleeve
228520				●	●	●				
228633				●	●	●				
228989				●	●		●			
228990				●	●			●		
428311		●			●					●
228521		●			●	●				
228634		●			●		●			
228991		●			●			●		
228992		●			●				●	
428312		●			●					●
228354	●				●	●	●			
228987	●				●	●		●		
228988	●				●	●			●	
428313	●				●					●
228599	●				●	●	●			

MAXPRO200® LongLife® air and oxygen plasma cutting system



Maximized productivity, easy operation, reliable performance.

The MAXPRO200 plasma cutting system achieves impressive cut speeds, consistent cut quality and exceptional consumable life with air or oxygen plasma gas. Optimized cutting parameters are automatically set and controlled in one step for easy operation. Engineered for heavy-duty, high capacity mechanized and handheld cutting and gouging, the MAXPRO200 delivers reliable performance across a wide range of industrial applications.

Maximized productivity

MAXPRO200 combines fast cutting speeds and quick process changes to maximize productivity.

- The fastest cut speeds in its class produce more finished parts per hour.
- Engineered with 100% duty cycle for the most demanding production environments.
- Quickly transition between cutting, gouging, mechanized and handheld processes with automatic settings, tool free leads and quick disconnect torches.

Easy operation

The easiest plasma system in its class for air and oxygen plasma cutting – easy to install, easy to operate, easy to maximize performance.

- Intuitive one step interface and automatic gas control deliver consistent results without operator intervention.
- Advanced diagnostics simplify troubleshooting and service.
- Optional serial communications allow full control of the system from the CNC.



Technologies

- Chambered swirl ring** gradually reduces gas pressure at the end of the cut to stabilize the hafnium insert prior to arc termination; this extends nozzle and electrode life.
- Conical Flow™** nozzle technology increases arc energy density for superior cut quality with little dross.

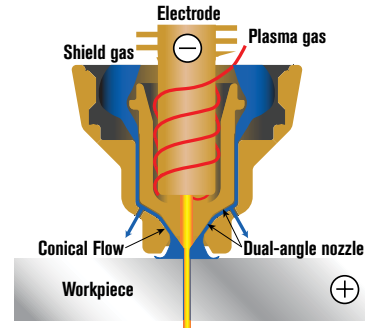

Conical Flow

- CoolFlow™** delivers enhanced cooling of the nozzle through key features such as a deep groove, angled o-ring seal and specific shoulder contact for increased nozzle life and cut quality.

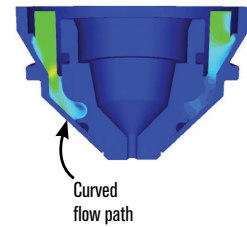

CoolFlow

- HyLife®** extends electrode life and lowers operating costs.
- Inline valve process** is a valve in the lead that controls the timing and pressure of cut-flow and pre-flow processes; this contributes to LongLife technology, extending consumable life in mild steel cutting.

- LongLife®** ramps current and gas flow up and down in a tightly controlled manner to reduce electrode and nozzle erosion.

- TrueFlow™** allows for centered electrode alignment with the water tube to ensure optimal cooling, which increases life and produces a higher and consistent cut quality.

- Tool free lead connection** allows leads to be easily disconnected.

- Tool free nozzle** allows consumables to be easily changed out.

- Vented shield** is electrically isolated to prevent double arcing, the vent holes around the orifice stabilize the arc, cool the consumables, and protect them from spatter. These features improve piercing capabilities and increase consumable life.

Fast cutting speeds = maximum productivity

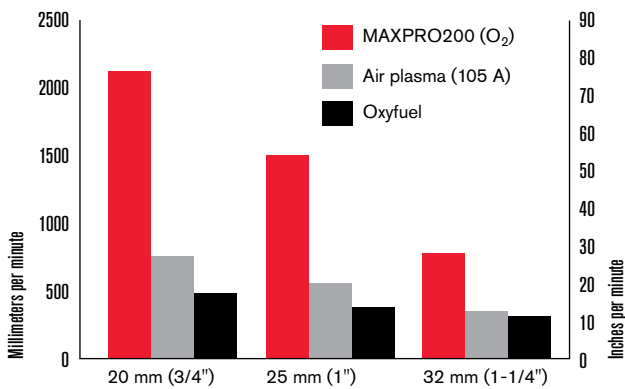

MAXPRO200® consumables – machine torch

Technologies

Chambered swirl ring

Conical Flow™

CoolFlow™

LongLife®

TrueFlow™

Vented shield

Tool free lead connection

Tool free nozzle

Inline valve process



Mild steel/stainless steel/aluminum consumables

	Amperage	Shield	Shield cap	Nozzle	Swirl ring	Electrode	Water tube
Air	50 A	220532	220936	220890	220529	220528	220521
			220935 without tab				
	130 A	220536	220936	220892	220488	220487	220521
			220935 without tab				
200 A	420045	220936	220936	420044	220488	220937	220521
			220935 without tab				



Mild steel consumables

	Amperage	Shield	Shield cap	Nozzle	Swirl ring	Electrode	Water tube
O ₂	50 A	220532	220936	220891	220529	220528	220521
			220935 without tab				
	130 A	220491	220936	220893	220488	220487	220521
			220935 without tab				
	130 A CCW	220491	220534	220893	420796	220487	220521
			220533 without tab				
200 A	220832	220936	220831	220834	220937	220521	
		220935 without tab					
200 A CCW	220832	220534	220831	420795	220937	220521	
			220533 without tab				



Stainless steel/aluminum consumables

	Amperage	Shield	Shield cap	Nozzle	Swirl ring	Electrode	Water tube
N ₂	130 A	220536	220936	220892	220529	020415	220521
			220935 without tab				
	200 A	420045	220936	420044	220529	020415	220521
			220935 without tab				



MAXPRO200® torch assembly options – machine

Standard leads

Part number	Lead length
229477	7.5 m (25')
229478	15 m (50')
229479	23 m (75')
229480	30 m (100')

Mounting sleeves

	Part number	Description	Length	Diameter
1	220943	Standard mounting sleeve (2" outside diameter)	279.4 mm (11")	50.8 mm (2")
	220942	Standard mounting sleeve (1.75" outside diameter)	279.4 mm (11")	44.45 mm (1.75")

Torch options

	Part number	Description
2	420087	Straight torch (standard)
3	420033	Quick-disconnect receptacle (option)
4	220921	Quick-disconnect torch

Additional parts available (not shown)

Part number	Description
228937	Machine torch (straight torch, set of 200 A consumables)
104119	Consumables removal tool
428013	Machine torch consumables starter kit
027055	Silicone lubricant for o-rings
028872	Torch coolant – Cool solution: 70/30 PG, 1-gal.
807700	MAXPRO200 instruction manual

See page 58 to learn about the value of preventive maintenance.



Quick-disconnect machine torch



Straight machine torch

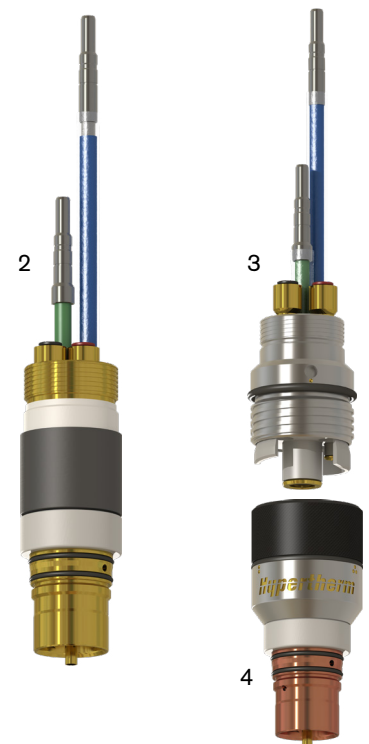
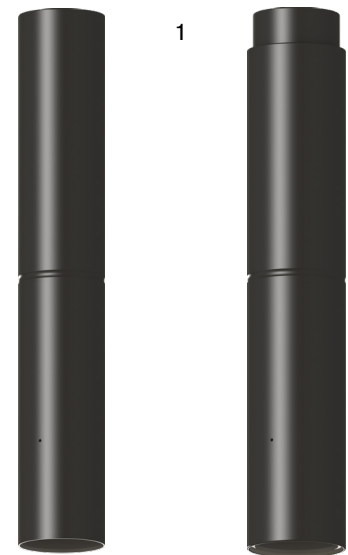

MAXPRO200[®] consumables – hand torch

Technologies

Chambered swirl ring

Conical Flow™

CoolFlow™

LongLife®

TrueFlow™

Vented shield

Tool free lead connection

Tool free nozzle

Inline valve process



Mild steel/stainless steel/aluminum consumables

	Amperage	Shield	Shield cap	Nozzle	Swirl ring	Electrode	Water tube
Air	50 A	420063	220935	220890	220529	220528	220521
	130 A	420061	220935	220892	220488	220487	220521
	200 A	420058	220935	420044	220488	220937	220521
	200 A gouging	420067	420793	420066	220488	220937	220521



Mild steel consumables

	Amperage	Shield	Shield cap	Nozzle	Swirl ring	Electrode	Water tube
O ₂	50 A	420063	220935	220891	220529	220528	220521
	130 A	420062	220935	220893	220488	220487	220521
	200 A	420059	220935	220831	220834	220937	220521
	200 A gouging	420067	420793	420066	220834	220937	220521



MAXPRO200[®] torch assembly options – hand

Standard leads

Part number	Lead length
428131	7.5 m (25')
428132	15 m (50')
428133	23 m (75')
428134	30 m (100')

90° hand torch

	Part number	Description
1	228985	Handle replacement kit
2	428109	Torch main body
	428014	Handheld consumables starter kit
	228980	90 degree hand torch assembly with 7.5 m (25') lead
	228981	90 degree hand torch assembly with 15 m (50') lead
	228982	90 degree hand torch assembly with 23 m (75') lead
	228983	90 degree hand torch assembly with 30 m (100') lead

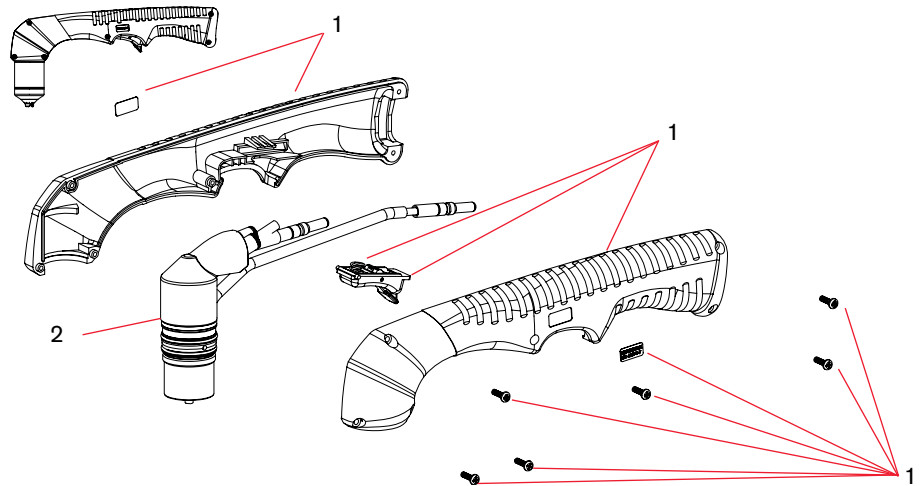

65° hand torch

	Part number	Description
1	228986	Handle replacement kit
2	428108	Torch main body
	428014	Handheld consumables starter kit
	228976	65 degree hand torch assembly with 7.5 m (25') lead
	228977	65 degree hand torch assembly with 15 m (50') lead
	228978	65 degree hand torch assembly with 23 m (75') lead
	228979	65 degree hand torch assembly with 30 m (100') lead

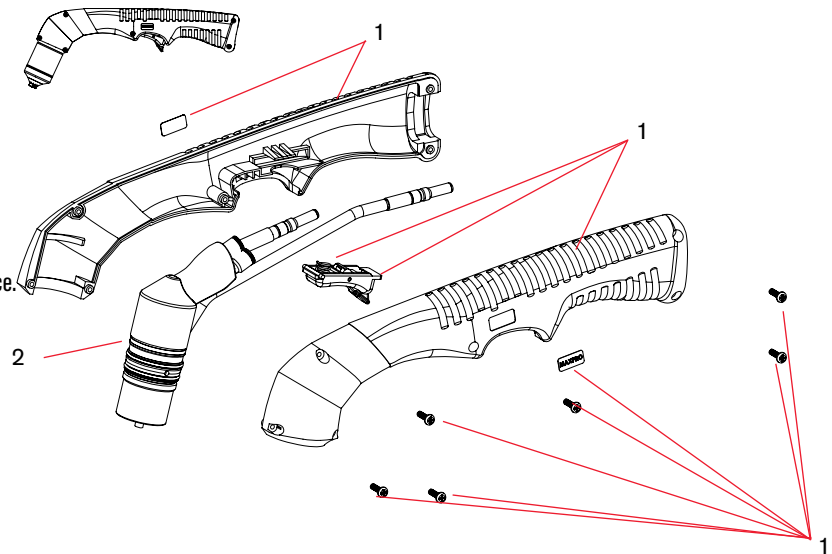

See page 58 to learn about the value of preventive maintenance.

SilverPlus® consumables technology



SilverPlus is a proven electrode technology that extends consumable life and significantly reduces operating costs.

On average, SilverPlus electrode technology doubles the life of the electrode and nozzle compared to copper electrodes.

SilverPlus technology permits the user to burn the electrode deeper and helps to preserve the size and shape of the nozzle orifice maintaining excellent cut quality throughout the life of the consumables.

Improve your cutting process:

- Twice the life of electrode and nozzle
- Excellent cut quality
- Consistent performance

The SilverPlus difference

Unlike other copper/silver electrodes, SilverPlus electrodes are manufactured with a robust solid-state copper/silver weld joint insuring consistent performance from every electrode.

Because the silver and copper are welded prior to electrode machining, the hafnium is guaranteed to be perfectly centered in the electrode giving the most reliable performance.

The friction welded silver/copper bond is near forge quality giving the best possible electrical and thermal conductivity which maximizes life and consistency.

Hypertherm consumables are designed with critical-to-function tolerances and manufactured with the highest levels of precision and repeatability delivering highly reliable and repeatable performance.



How the technology works

SilverPlus electrodes utilize a hafnium/silver interface at the point of electrical transfer. The hafnium/silver interface extracts more heat and has a stronger bond, enabling a deeper pit depth in the hafnium. This means that you will get double the life compared to standard copper electrodes.

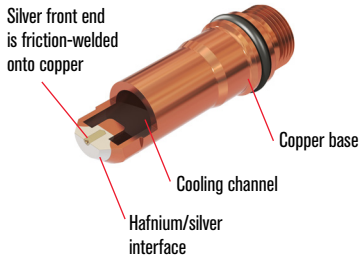

Our testing

To better simulate a production application, Hypertherm programs ramp down errors into 20% of our cuts while testing. This means that we purposely commit a cutting error, like running off the plate, in one out of five cuts made in the lab. Testing at Hypertherm is conducted until we reach the end of consumable life.

In a production environment, you should experience at least twice the life from SilverPlus than you do from standard copper electrodes from 80 to 260 amps. SilverPlus electrodes used in applications that cut from 300 to 400 amps generally last 50% longer than copper.

System	Amperage	Part number
HPR®/HPRXD®	80 A	420566
HPR®/HPRXD®	130 A	220665
HPR®/HPRXD®	200 A	220666
HPR®/HPRXD®	260 A	220668
HPR400XD®	400 A	420530
HSD130®	130 A	420185
HT2000®	200 A	220084
HT2000® with HyPro2000™ torch	130 A	420185
HT2000® with HyPro2000 torch	200 A	220925
MAX200®	200 A	220083
HT4400®	200-400 A	220412
HD3070®	100 A	220408
HT4001®	260 A	220397
HT4000®	400 A	220397
HT400®	400 A	220397

Before you cut

Purge torch

After each parts change, purge the torch for at least 30 seconds to remove residual moisture which can damage a SilverPlus® electrode.

Prevent leaks

Apply o-ring lubricant to all consumable o-rings. After purging the torch, make sure all o-ring seals are tight and there are no torch coolant leaks.

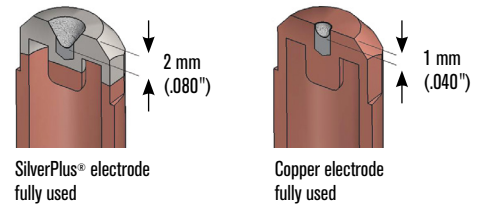

SilverPlus electrodes burn almost twice as deep as standard copper electrodes, doubling SilverPlus life over a standard copper electrode.

Maximize consumable life

Distinct from all-copper electrodes, SilverPlus electrodes wear in a way that greatly reduces debris build up on the inside wall of the nozzle which reduces damage to the nozzle orifice. As a result, SilverPlus technology doubles the life of both the electrode and the nozzle.

Use electrode to full life

A fully used SilverPlus electrode will have a pit depth of 2.0 mm (.080"). This is deeper than the recommended pit depth for standard copper electrodes of 1.0 mm (.040").

Adjust arc voltage

In order to maintain the proper torch-to-plate distance in systems using a voltage-based height control, arc voltage should be increased 5-volts at the time that you would replace a copper electrode.

Average cut quality over life (80-260 A)*

Oxygen 20/20 parts life and cut quality, 10 to 20 mm (3/8 to 3/4") mild steel

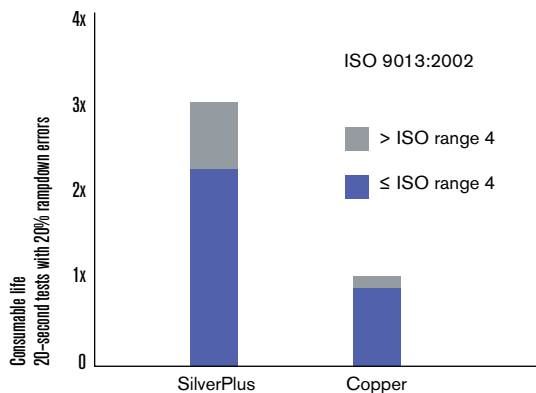

*Data from HyPerformance® HPRXD® 80-260 A, HSD130® and HyPro2000™ lab testing. Production results may vary.

The cut quality ranges, shown in these test results, meet the ISO 9013:2002 industrial standard that defines cut quality of thermally cut parts. The lower the range, the smaller the angle on the cut face.

Scan this tag with a smart phone to watch videos and learn more about SilverPlus technology



XD technology upgrade kits for HPR260/HPR130®

SECOND
LIFE



In four short hours, give your HPR plasma cutting system a Second Life



Hour 1

Remove old torch and leads, open and clean system.



Hour 2

Install new board, evaluate system components and finish cleaning.



Hour 3

Install new torch and leads, configure new settings in the CNC.



Hour 4

Perform test cutting and optimize the cutting process.

Hypertherm's XD technology upgrade kit includes a new XD control board, push-connect gas fittings, leads, upgraded torch and consumable technologies, and a visit from a trained technician. This technician will clean, perform maintenance, and upgrade your HPR cutting system to optimize your cutting process and give a second life to your cutting operation.

Customers who have made this upgrade report:

- Improved cut angularity – especially on holes
- Improved consumable life
- Increased piercing capability through PowerPierce® technology
- Consistent cut quality over the life of consumables
- The XD torch is more robust than the standard HPR torch



Scan this tag with a smart phone
to learn more about second life

XD technology upgrade kits

What to order:

1. Upgrade kit

Part number	Description
228524	New control board with firmware for the power supply
	Gas console firmware for both auto gas selection console and metering console, and tool to remove firmware chips
	Adapter fittings for metering console, to connect new torch leads to old style connectors on metering console
	Field service bulletin
	XD and PowerPierce labels

2. Torch assembly (order one)

Part number	Description	Notes
228520	HPR130XD torch with list of 130 A bevel consumables	Includes a quick-disconnect torch and receptacle, torch sleeve - length 181 mm (7"), and 1 set of consumables
228521	HPR260XD torch with list of 260 A bevel consumables	
228633	HPR130XD torch with list of 130 A consumables	
228634	HPR260XD torch with list of 260 A consumables	

3. Torch leads (order one)

228291	Standard torch leads, 2 m / 6'	Bevel torch leads are also available
228292	Standard torch leads, 3 m / 10'	
228293	Standard torch leads, 4.5 m / 15'	
228294	Standard torch leads, 6 m / 20'	
228295	Standard torch leads, 7.5 m / 25'	
228296	Standard torch leads, 10 m / 35'	
228297	Standard torch leads, 15 m / 50'	
228547	Standard torch leads, 20 m / 65'	

4. IHS ohmic contact wire (order one)

123983	IHS ohmic contact wire, 3 m / 10'	Necessary for ohmic sensing
123984	IHS ohmic contact wire, 6 m / 20'	
123985	IHS ohmic contact wire, 7.5 m / 25'	
123986	IHS ohmic contact wire, 9 m / 30'	
123987	IHS ohmic contact wire, 12 m / 40'	
123988	IHS ohmic contact wire, 15 m / 50'	
123989	IHS ohmic contact wire, 23 m / 75'	
123990	IHS ohmic contact wire, 30 m / 100'	
123991	IHS ohmic contact wire, 45 m / 150'	

5. Electronics kits

System	Electronics kit (contactor, relay, torch)	Contactor	Relay
HPR130XD	428268	003249	003149
HPR260XD (200-240 V)	428269	003217	003149
HPR260XD (380-600 V)	428272	003233	003149

Technologies

Chambered Swirl Ring	gradually reduces gas pressure at the end of the cut to stabilize the hafnium insert prior to arc termination; this extends nozzle and electrode life.
Conical Flow™	nozzle technology increases arc energy density for superior cut quality with little dross.
CoolFlow™	delivers enhanced cooling of the nozzle through key features such as a deep groove, angled o-ring seal and specific shoulder contact for increased nozzle life and cut quality.
Dimpled electrode	extends electrode life by preventing material from blowing on the nozzle when first ignited.
HDi®	delivers HyDefinition® quality to thin stainless steel cutting from 3 mm (12 ga.) to 6 mm (1/4").
HyDefinition®	vented nozzle technology aligns and focuses the plasma arc for powerful precision cutting, superior quality, and consistency.
HyLife®	extends electrode life and lowers operating costs.
LongLife®	ramps current and gas flow up and down in a tightly controlled manner to reduce electrode and nozzle erosion.
PowerPierce®	liquid cooled shield technology repels molten metal during piercing. Enables robust production pierce capability up to 50 mm (2") mild steel and 75 mm (3") stainless steel and aluminum. Delivers speed and thickness capabilities.
SilverPlus®	Silver front end tip which dramatically extends electrode and nozzle life, reduces the number of change outs and significantly reduces operating cost. For more information on SilverPlus technology, see page 21.
TrueFlow™	allows for centered electrode alignment with the water tube to ensure optimal cooling, which increases life and produces a higher and consistent cut quality.

Hypertherm recommends replacement of the main contactor and pilot arc relay as part of this upgrade.

Contact your Hypertherm channel partner to learn about additional torch discounts available with this upgrade

HyPerformance® HPR260/130® consumables



Technologies

Chambered swirl ring

Conical Flow™

Dimpled electrode

HyDefinition®

HyLife®

LongLife®

SilverPlus®

TrueFlow™

Mild steel consumables

HPR		Amperage	Shield cap	Shield	Nozzle retaining cap	Nozzle	Swirl ring	Electrode	SilverPlus electrode	Water tube	
260	130										
●	●	30 A		220173	220194	220313	220193	220180	220192	-----	220340
●	●	30 A	CCW	220173	220194	220314	220193	220306	220192	-----	220340
●	●	50 A		220173	220555	220313	220554	220553	220552	-----	220340
●	●	50 A	CCW	220173	220555	220314	220554	220549	220552	-----	220340
●	●	80 A		220173	220189	220176	220188	220179	220187	420566	220340
●	●	80 A	CCW	220173	220189	220304	220188	220305	220187	420566	220340
●	●	130 A		220173	220183	220176	220182	220179	220181	220665	220340
●	●	130 A	CCW	220173	220183	220304	220182	220305	220181	220665	220340
●		200 A		220398	220356	220355	220354	220353	220352	220666	220340
●		200 A	CCW	220398	220356	220351	220354	220350	220352	220666	220340
●		260 A		220398	220440	220433	220439	220436	220435	220668	220340
●		260 A	CCW	220398	220440	220441	220439	220442	220435	220668	220340
●		260 A	CCW bevel	220398	220545	220793	220542	220442	220541	-----	220571
●	●	130 A	Bevel	220398	220645	220603	220646	220179	220649	-----	220700
●		260 A	Bevel	220398	220545	220603	220542	220436	220541	-----	220571

Stainless steel consumables

HPR		Amperage	Shield cap	Shield	Nozzle retaining cap	Nozzle	Swirl ring	Electrode	Water tube		
260	130										
●	●	45 A		220173	220202	220304		220201	220180	220308	220340
●	●	80 A		220173	220338	220304		220337	220179	220339	220340
●	●	130 A		220173	220198	220304	H35	220197	220179	220307	220340
●	●					220176	N ₂				
●		200 A		220398	220345	220344		220343	220342	220307	220340
●		260 A		220398	220407	220344		220406	220405	220307	220340
●	●	130 A	Bevel	220398	220609	220608	H35	220656	220179	220606	220571
●	●					220608	N ₂				
●		260 A	Bevel	220398	220609	220608		220607	220405	220606	220571

Aluminum consumables

HPR		Amperage	Shield cap	Shield	Nozzle retaining cap	Nozzle	Swirl ring	Electrode	Water tube			
260	130											
●	●	45 A		220173	220202	220176		220201	220180	220308	220340	
●	●	130 A		220173	220198	220304	H35	220197	220179	220307	H35	220340
●	●					220176	N ₂			220181	Air	
●		200 A		220398	220345	220347		220346	220342	220307	220340	
●		260 A		220398	220407	220344		220406	220405	220307	220340	

HyPerformance® HPR260/130® torch assembly options



Standard leads

Part number		Lead length
6' gas	8' gas	
128986	-----	2 m (6')
128935	-----	3 m (10')
128934	228040	4.5 m (15')
128784	228043	7.5 m (25')
128987	228065	10 m (35')
128785	228045	15 m (50')
128988	228066	20 m (65')

Robotic/Bevel leads

Part number		Lead length
6' gas	8' gas	
228075	-----	2 m (6')
228076	228077	3 m (10')
228079	228061	4.5 m (15')
228081	228062	7.5 m (25')
228083	228084	10 m (35')
228086	228063	15 m (50')
228088	228089	20 m (65')

Torch mounting sleeves

	Part number	Description	Length	Diameter
1	220232	Standard	199 mm (7.8")	50.8 mm (2")
	220516	Extended	283 mm (11")	50.8 mm (2")
	220546	Bevel/Rotational (included in bevel receptacle)	126 mm (5")	50.8 mm (2")

Quick-disconnect receptacle

	Part number	Description
2	220163	Standard
	220573	Bevel (includes sleeve)

HyPerformance quick-disconnect torch main body

	Part number
3	220162

Additional parts available (not shown)

Part number	Description
128818	Machine torch
027055	Silicone lubricant for o-rings
104269	2" spanner wrench
004630	Electrode pit depth gauge
104119	Consumables removal tool
804960	HPR130 Auto gas instruction manual
804570	HPR130 Manual gas instruction manual
805000	HPR260 Auto gas instruction manual
804940	HPR260 Manual gas instruction manual
028872	Torch coolant - Cool solution: 70/30 PG, 1-gal.
128879	Torch rebuild kit

See page 58 to learn about the value of preventive maintenance.

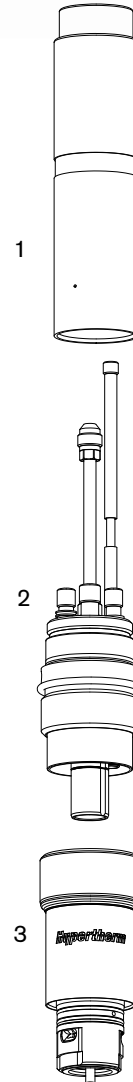

XD technology upgrade kits available! See pages 22 and 23



HyPro2000™ upgrade torch for MAX200®



The HyPro2000 for the MAX200 provides increased productivity through 25% faster speeds, 75% longer life and a quick-disconnect torch

25% Increase in cutting speed

- HyPro2000 technology dramatically improves productivity with increased cut speeds of 25%, compared to the standard MAX200.

Quick-disconnect torch

- The HyPro2000 torch is a quick-disconnect with an easy alignment feature.

Cut quality over life (200 A)

12 mm (1/2") mild steel, 15 m (50') leads

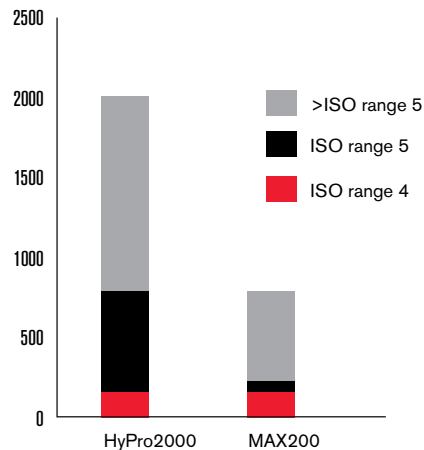

The graph shows tested HyPro2000 consumables improving life by at least 75% over MAX200 standard copper

75% Increase in consumable life

- HyPro2000 consumable technology dramatically reduces operating cost with a 75% increase in consumable life, compared to the standard MAX200 copper electrode.

“As a steel structure manufacturer productivity is critical to our success. By simply retrofitting our recently purchased MAX200 with the new HyPro2000 torch, we’ve realized a 25% increase in hourly part production with the 30% increase in cutting speeds and improved consumable life at 200 amps. We are thrilled to have gained such a dramatic improvement in productivity for such a minimal investment.”

– Mr. Claude Simard,
Owner Jean Simard et Fils P.D.L. Lte. Trois-Rivieres,
QC, Canada

Technologies

Chambered Swirl Ring	gradually reduces gas pressure at the end of the cut to stabilize the hafnium insert prior to arc termination; this extends nozzle and electrode life.
Conical Flow™	nozzle technology increases arc energy density for superior cut quality with little dross.
CoolFlow™	delivers enhanced cooling of the nozzle through key features such as a deep groove, angled o-ring seal and specific shoulder contact for increased nozzle life and cut quality.
HyLife®	extends electrode life and lowers operating costs.
LongLife®	ramps current and gas flow up and down in a tightly controlled manner to reduce electrode and nozzle erosion.
TrueFlow™	allows for centered electrode alignment with the water tube to ensure optimal cooling, which increases life and produces a higher and consistent cut quality.
Vented Shield	is electrically isolated to prevent double arcing, the vent holes around the orifice stabilize the arc, cool the consumables, and protect them from spatter. These features improve piercing capabilities and increase consumable life.



Scan this tag with a smart phone to watch the installation demonstration video

HyPro2000™ upgrade consumables for MAX200®

- Technologies
- Chambered swirl ring
- Conical Flow™
- CoolFlow™
- HyLife®
- LongLife®
- TrueFlow™
- Vented shield



Mild steel /stainless steel/aluminum consumables

	Amperage	Shield	Retaining cap	Nozzle	Swirl ring	Electrode	Water tube
Air	50 A	220532	220936	220890	220529	220528	220521
			220935 without tab				
	130 A	220536	220936	220936	220892	220488	220487
220935 without tab							
200 A	420045	220936	220936	420044	220488	220937	220521
			220935 without tab				



Mild steel consumables

	Amperage	Shield	Retaining cap	Nozzle	Swirl ring	Electrode	Water tube
O ₂	130 A	220536	220936	220892	220488	220487	220521
			220935 without tab				
	200 A	420045	220936	220936	420044	220488	220937
220935 without tab							



Stainless steel/aluminum consumables

	Amperage	Shield	Retaining cap	Nozzle	Swirl ring	Electrode	Water tube
N ₂	200 A	420045	220936	420044	220529	020415	220521
			220935 without tab				



HyPro2000™ upgrade torch assembly options for MAX200®



HyPro2000 straight torch



HyPro2000 quick-disconnect torch

Torch upgrade kits

Part number	Kit	Description
228908	HyPro2000 for MAX200® quick-disconnect	Includes: machine torch (loaded with consumables), quick-disconnect receptacle, mounting sleeves (2" and 1.75"), 200 A Air/O ₂ electrodes (2), 200 A Air/O ₂ nozzles (2), silicone lubricant for o-rings, consumable removal tool, plastic tube for hoses, plasma gas extension hose, operating manual.
428256	HyPro2000 for MAX200 straight torch with 45 mm (1.75") sleeve	Includes: machine torch (loaded with 200 A consumables), mounting sleeve 45 mm (1.75"), silicone lubricant for o-rings, consumable removal tool, plastic tube for hoses, 200 A Air cut charts.
428255	HyPro2000 for MAX200 straight torch with 50 mm (2") sleeve	Includes: machine torch (loaded with 200 A consumables), mounting sleeve 50 mm (2"), silicone lubricant for o-rings, consumable removal tool, plastic tube for hoses, 200 A Air cut charts.

Standard leads

Part number	Lead length
028454	3 m (10')
028455	4.5 m (15')
028456	6 m (20')
028383	7.5 m (25')
028457	9 m (30')
028458	10 m (35')
028459	12 m (40')
028460	14 m (45')
028384	15 m (50')
028773	18 m (60')
028599	23 m (75')
028781	30 m (100')

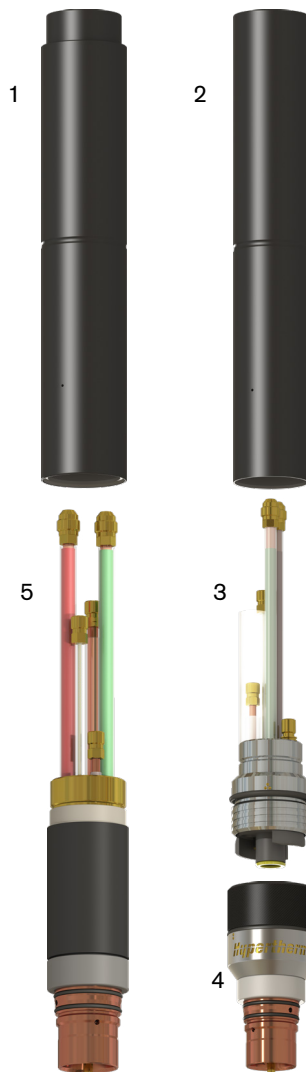

Mounting sleeves

	Part number	Length	Diameter
1	220943	279.4 mm (11")	50.8 mm (2")
2	220942	279.4 mm (11")	44.45 mm (1.75")

Torch options

	Part number	Description
3	220913	Quick-disconnect receptacle
4	220921	HyPro2000 Quick-disconnect torch
5	220961	HyPro2000 Straight torch

Additional parts available (not shown)

Part number	Description
104119	Consumables removal tool
027055	Silicone lubricant for o-rings
028872	Torch coolant – Cool solution: 70/30 PG, 1-gal.

See page 58 to learn about the value of preventive maintenance.

MAX200® standard consumables – machine torch



Technologies

Chambered swirl ring

HyLife®

SilverPlus®

Vented shield

Mild steel consumables

Plasma gas	Amperage	Process	Shield	Retaining cap*	Nozzle	Swirl ring	Electrode	SilverPlus electrode	Water tube
Air	40 A		020688	020423	020689	020613	120547	-----	020963
O ₂	100 A		020448	020423	020616	020617	120547	-----	020963
Air	100 A		020448	020423	020611	020607	120547	-----	020963
N ₂	200 A		020424	020423	020608	020607	020415	-----	020963
Air	200 A		020424	020423	020608	020607	220021	-----	020963
O ₂	200 A		020424	020423	020605	020604	220021	220083	020963
Air	200 A	Gouging	020485	020423	020615	020607	220021	-----	020963
O ₂	200 A	Bevel	120260	020423	120259	120833	120258	-----	120257

Stainless steel consumables

Plasma gas	Amperage	Process	Shield	Retaining cap*	Nozzle	Swirl ring	Electrode	Water tube
Air	40 A		020688	020423	020689	020613	120547	020963
Air	100 A		020448	020423	020611	020607	120547	020963
H35	100 A		020448	020423	020611	020607	020415	020963
Air	200 A		020424	020423	020608	020607	220021	020963
H35	200 A		020602	020423	020608	020607	020415	020963
N ₂	200 A		020424	020423	020608	020607	020415	020963
H35	200 A	Gouging	020485	020423	020615	020607	020415	020963

Aluminum consumables

Plasma/ Shield gas	Amperage	Process	Shield	Retaining cap*	Nozzle	Swirl ring	Electrode	Water tube
Air	40 A		020688	020423	020689	020613	120547	020963
Air	100 A		020448	020423	020611	020607	120547	020963
H35	100 A		020448	020423	020611	020607	020415	020963
Air	200 A		020448	020423	020608	020607	220021	020963
N ₂ /Air	200 A		020424	020423	020608	020607	020415	020963
N ₂ /CO ₂	200 A		020424	020423	020608	020607	020415	020963
H35/N ₂	200 A		020602	020423	020608	020607	020415	020963
H35/N ₂	200 A	Gouging	020485	020423	020615	020607	020415	020963

*120837 retaining cap with IHS tab



Consumables for underwater cutting

Plasma gas	Amperage	Material	Shield	Retaining cap	Nozzle	Swirl ring	Electrode	Water tube
Air	100 A	MS, SS, AL	020448	020423	020611	020607	120547	020963
O ₂	100 A	MS	020448	020423	020616	020617	120547	020963
Air	200 A	MS, SS, AL	020424	020423	020608	020607	220021	020963
O ₂	200 A	MS	020424	020423	020605	020604	220021	020963
O ₂	200 A	SS	020424	020423	020608	020607	220021	020963
N ₂	200 A	SS, AL	020424	020423	020608	020607	020415	020963



MAX200® standard torch assembly options – machine

Standard leads

	Part number	Lead length
1	028454	3 m (10')
	028455	4.5 m (15')
	028456	6 m (20')
	028383	7.5 m (25')
	028457	9 m (30')
	028458	10 m (35')
	028459	12 m (40')
	028460	14 m (45')
	028384	15 m (50')
	028773	18 m (60')
	028599	23 m (75')

Mounting sleeves

	Part number	Description	Diameter
2	120894	2" sleeve	50.8 mm (2")
	020431	1.75" sleeve	44.5 mm (1.75")
	020041	2" sleeve for stainless steel torch	50.8 mm (2")

Torch options

	Part number	Description	Diameter
3	120584	Standard	44.5 mm (1.75")
	120356	Stainless steel	50.8 mm (2")

Additional parts available (not shown)

Part number	Description
228010	Preventive maintenance kit (torch main body, coolant, light bulb, contactor, relay)
128380	Machine torch – 2" sleeve (torch, 2" sleeve, consumables)
128364	Machines torch – 1.75" sleeve (torch, 1.75" sleeve, consumables)
128365	Stainless steel machine torch (torch, sleeve, consumables)
020536	Lead insulator (9/16 X 2.5 Tef)
044027	O-ring (Buna-N)
027055	Silicone lubricant for o-rings
800870	MAX200 machine torch plasma arc cutting system instruction manual
028872	Torch coolant – Cool solution: 70/30 PG, 1-gal.
800980	MAX200 hand torch plasma arc cutting system instruction manual

See page 58 to learn about the value of preventive maintenance.



128380 – Standard body – 2" sleeve



120356 – Stainless steel body

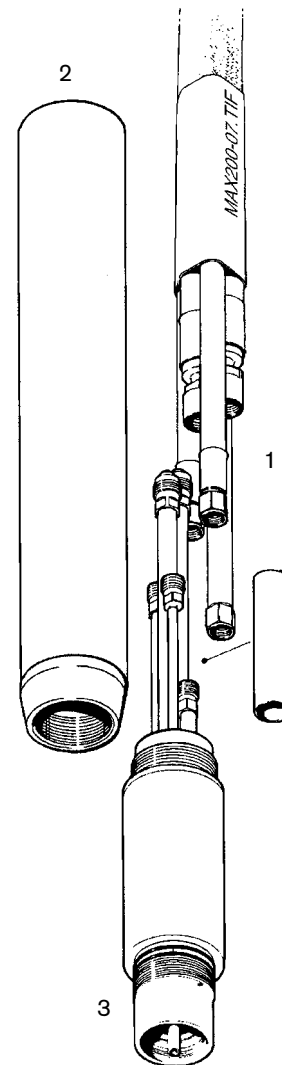

MAX200[®] consumables – PAC200 T/E hand torch

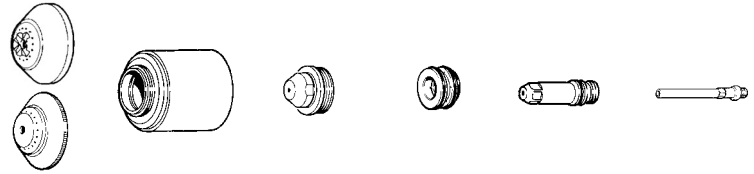

Mild steel/stainless steel/aluminum consumables

Plasma gas	Shield gas	Amperage	Shield	Shield cap	Nozzle	Swirl ring	Electrode	Water tube
Air	Air	100 A	020919	020915	020611	020607	120547	020963
	Air	200 A	020918	020915	020608	020607	220021	020963
N ₂	CO ₂	200 A	020918	020915	020608	020607	020415	020963

Stainless steel/aluminum consumables

Plasma gas	Shield gas	Amperage	Shield	Shield cap	Nozzle	Swirl ring	Electrode	Water tube
H35	N ₂	100 A	020919	020915	020611	020607	020415	020963
N ₂	Air	200 A	020918	020915	020608	020607	020415	020963

Mild steel consumables

Plasma gas	Shield gas	Amperage	Shield	Shield cap	Nozzle	Swirl ring	Electrode	Water tube
O ₂	Air	100 A	020919	020915	020616	020617	220021	020963
	Air	200 A	020918	020915	020605	020604	220021	020963

Stainless steel consumables

Plasma gas	Shield gas	Amperage	Shield	Shield cap	Nozzle	Swirl ring	Electrode	Water tube
H35	N ₂	200 A	020920	020915	020608	020607	020415	020963

Aluminum consumables

Plasma gas	Shield gas	Amperage	Shield	Shield cap	Nozzle	Swirl ring	Electrode	Water tube
H35	N ₂	200 A	020918	020915	020608	020607	020415	020963

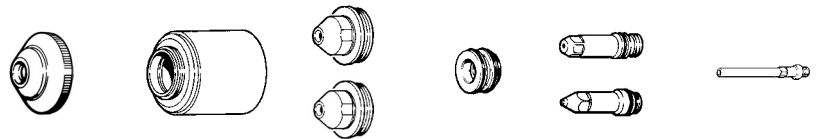

Gouging – mild steel consumables

Plasma gas	Shield gas	Amperage	Shield	Shield cap	Nozzle	Swirl ring	Electrode	Water tube
Air	Air	200 A	020891	020882	020615	020607	220021	020913
H35	Air	200 A	020891	020882	020934	020607	020933	020913

Gouging – stainless steel/aluminum consumables

Plasma gas	Shield gas	Amperage	Shield	Shield cap	Nozzle	Swirl ring	Electrode	Water tube
H35	N ₂	200 A	020891	020882	020934	020607	020933	020913



MAX200[®] torch assembly options – PAC200 T/E hand

Assembly

	Part number	Description
	073189*	PAC200T 90° hand cutting torch assembly with 25' (7.6 m) leads
	073190*	PAC200T 90° hand cutting torch assembly without leads
	073111*	PAC200E 65° hand gouging torch assembly with 25' (7.6 m) leads
	073188*	PAC200E gouging torch assembly without leads
	029865	Torch-to-power supply with 25' (7.6 m) leads
	028715	Torch-to-power supply with 50' (15.2 m) leads
	028716	Torch-to-power supply with 75' (22.9 m) leads
	028717	Torch-to-power supply with 100' (30.5 m) leads
	028718	Torch-to-power supply with 125' (38.1 m) leads
	028719	Torch-to-power supply with 150' (45.8 m) leads
1	120045	Torch main body, PAC200T hand torch 90°
2	020908	Torch main body, PAC200E gouging torch 65°
3	001412	Handle, PAC200T 90° (both halves included)
	001440	Handle, PAC200E 65° (both halves included) (not shown)
4	075365	Screw, #6 x 3/4", phillips head, pan (six required)
5	046065	Insul. tube, 9/16 ID x.03 WL, PTFE** (included with lead sets)
6	027254	Trigger spring, PAC200T/E
7	002244	Safety trigger, PAC200T/E
8	005094	Push button switch (included with lead sets listed above)
9	074069	Splice (two required)
10	001217	Boot
11	020881	Hand heat shield, PAC200E gouging torch
12	044027	O-ring, Buna (two required)
	027347	Water tube replacement tool
	023345	Work lead with clamp 25' (7.6 m)
	023420	Work lead with clamp 50' (15.2 m)

* Assembly includes consumables

** PolyTetraFluoroEthylene is a fluorocarbon-based polymer and is commonly abbreviated PTFE. The Teflon[®] brand of PTFE is manufactured only by DuPont and is not sold by Hypertherm. Hypertherm purchases other brands of PTFE from various high quality manufacturers.

See page 58 to learn about the value of preventive maintenance.



PAC200T 90° hand torch

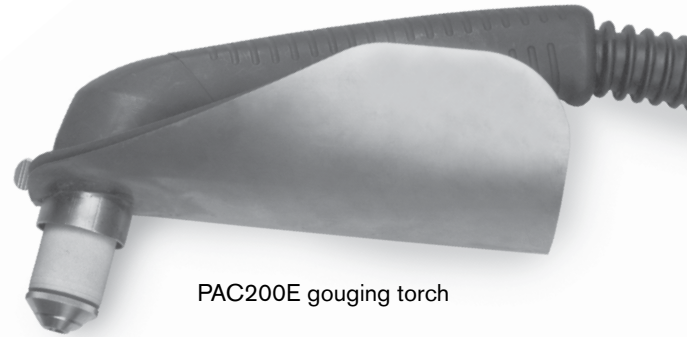

PAC200E gouging torch

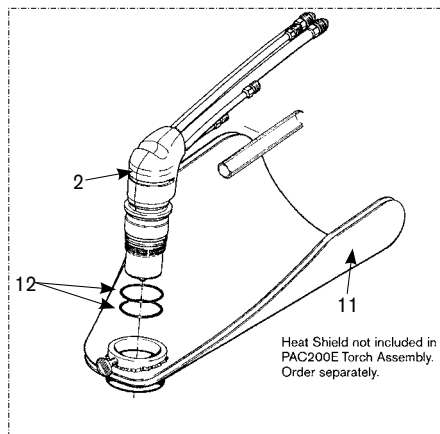

PAC200E:Torch for gouging with hand heat shield.

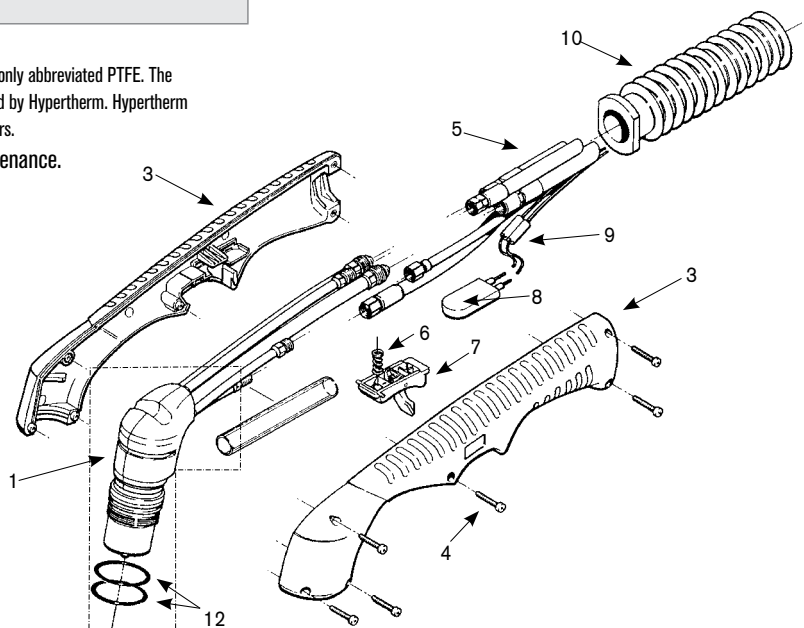

PAC200T

HyPro2000™ upgrade torch for HT2000®



The New HyPro2000 for the HT2000 provides increased productivity through 50% faster speeds, 75% longer life and a quick-disconnect torch.

50% Increase in cutting speed

- HyPro2000 technology dramatically improves productivity with increased cut speeds of 50% compared to the standard HT2000.

75% increase in consumable life

- HyPro2000 consumable technology dramatically reduces operating cost with significant increase in consumable life using SilverPlus®.

Quick-disconnect torch

- The HyPro2000 torch is a quick-disconnect with an easy alignment feature.

Cut quality over life (200 A)*
12 mm (1/2") mild steel

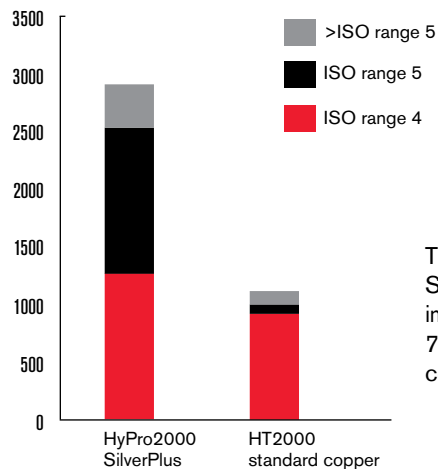

The graph shows HyPro2000 SilverPlus electrodes improving life by at least 75% over HT2000 standard copper.

*Results based on lab testing performed with torch manufacturer's recommended operating conditions. 20-second tests with 20% rampdown errors.



Plasma press test gauge, lubricant, HyPro2000 torch upgrade firmware, hose assemblies, consumable removal tool included with the upgrade kit.

“At NSC, we are very pleased with the performance of the New HyPro2000. Our productivity has improved with double-digit cut-speed increases and significant time reductions in consumable changes using the quick-disconnect torch system. Since the installation of the HyPro2000 torches we have enjoyed an increase in quality and productivity to an already reliable cutting system.”

- National Steel Car

Technologies

- Chambered Swirl Ring** gradually reduces gas pressure at the end of the cut to stabilize the hafnium insert prior to arc termination; this extends nozzle and electrode life.
- Conical Flow™** nozzle technology increases arc energy density for superior cut quality with little dross.
- CoolFlow™** delivers enhanced cooling of the nozzle through key features such as a deep groove, angled o-ring seal and specific shoulder contact for increased nozzle life and cut quality.
- HyLife®** extends electrode life and lowers operating costs.
- LongLife®** ramps current and gas flow up and down in a tightly controlled manner to reduce electrode and nozzle erosion.
- SilverPlus®** silver front end tip which dramatically extends electrode life, reduces the number of change outs and significantly reduces operating cost. For more information on SilverPlus technology, see page 21.

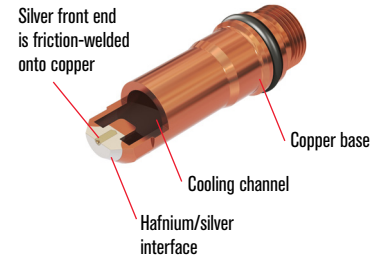

- TrueFlow™** allows for centered electrode alignment with the water tube to ensure optimal cooling, which increases life and produces a higher and consistent cut quality.
- Vented Shield** is electrically isolated to prevent double arcing, the vent holes around the orifice stabilize the arc, cool the consumables, and protect them from spatter. These features improve piercing capabilities and increase consumable life.



Scan this tag with a smart phone to watch the installation demonstration video

HyPro2000™ upgrade consumables for HT2000®

- Technologies
- Chambered swirl ring
- Conical Flow™
- CoolFlow™
- HyLife®
- LongLife®
- SilverPlus®
- TrueFlow™
- Vented shield



Mild steel consumables

	Amperage	Shield	Shield cap	Nozzle	Swirl ring	Electrode	SilverPlus electrode	Water tube
O ₂	50 A	220532	220936	220891	220529	220528	-----	220521
			220935 without tab				-----	
	130 A	220491	220936	220893	220488	220487	420185	220521
			220935 without tab					
200 A	220832	220936	220831	220834	220937	220925	220521	
			220935 without tab					



Mild steel /stainless steel/aluminum consumables

	Amperage	Shield	Shield cap	Nozzle	Swirl ring	Electrode	Water tube
Air	50 A	220532	220936	220890	220529	220528	220521
			220935 without tab				
	130 A	220536	220936	220892	220488	220487	220521
			220935 without tab				
200 A	420045	220936	420044	220488	220937	220521	
			220935 without tab				



Stainless steel/aluminum consumables

	Amperage	Shield	Shield cap	Nozzle	Swirl ring	Electrode	Water tube
N ₂	200 A	420045	220936	420044	220529	020415	220521
			220935 without tab				



HyPro2000™ upgrade torch assembly options for HT2000

Torch upgrade kits

Part number	Kit	Description
HyPro2000 Quick-disconnect torch		
228549	HyPro2000 (Systems prior to 2003) RHF serial number 2000-06450 and below LHF serial number 2lhf2000-000580 and below.	Includes: control board, machine torch (loaded with consumables), quick-disconnect receptacle, mounting sleeves (2" and 1.75"), 200 A O ₂ shield, 200 A O ₂ shield cap, 200 A O ₂ nozzles, 200 A O ₂ swirl ring, 200 A O ₂ SilverPlus® electrodes, 200 A O ₂ copper electrodes, silicone lubricant for o-rings, consumable removal tool, chip removal tool, chip upgrade, pressure gage, plastic tube for hoses, hose (24"), operating manual.
228550	HyPro2000 (2003–current systems) RHF serial number 2000-06451 and above LHF serial number 2lhf2000-000581 and above.	Includes: machine torch (loaded with consumables), quick-disconnect receptacle, mounting sleeves (2" and 1.75"), 200 A O ₂ shield, 200 A O ₂ shield cap, 200 A O ₂ nozzles, 200 A O ₂ swirl ring, 200 A O ₂ SilverPlus® electrodes, 200 A O ₂ copper electrodes, silicone lubricant for o-rings, consumable removal tool, chip removal tool, chip upgrade, pressure gage, plastic tube for hoses, hose (24"), operating manual.
HyPro2000 for punch presses		
228778	HyPro2000 (Systems prior to 2003) RHF serial number 2000-06450 and below. LHF serial number 2lhf2000-000580 and below.	Includes: control board, straight torch for punch presses, mounting sleeves (2" and 1.75"), 200 A O ₂ shield, 200 A O ₂ shield cap, 200 A O ₂ nozzles, 200 A O ₂ swirl ring, 200 A O ₂ SilverPlus® electrodes, 200 A O ₂ copper electrodes, silicone lubricant for o-rings, consumable removal tool, chip removal tool, chip upgrade, pressure gage, plastic tube for hoses, hose (24"), operating manual.
228777	HyPro2000 (2003 – current systems) HF serial number 2000-06451 and above LHF serial number 2lhf2000-000581 and above.	Includes: straight torch for punch presses, mounting sleeves (2" and 1.75"), 200 A O ₂ shield, 200 A O ₂ shield cap, 200 A O ₂ nozzles, 200 A O ₂ swirl ring, 200 A O ₂ SilverPlus® electrodes, 200 A O ₂ copper electrodes, silicone lubricant for o-rings, consumable removal tool, chip removal tool, chip upgrade, pressure gage, plastic tube for hoses, hose (24"), operating manual.



HyPro2000 straight torch



HyPro2000 quick-disconnect torch

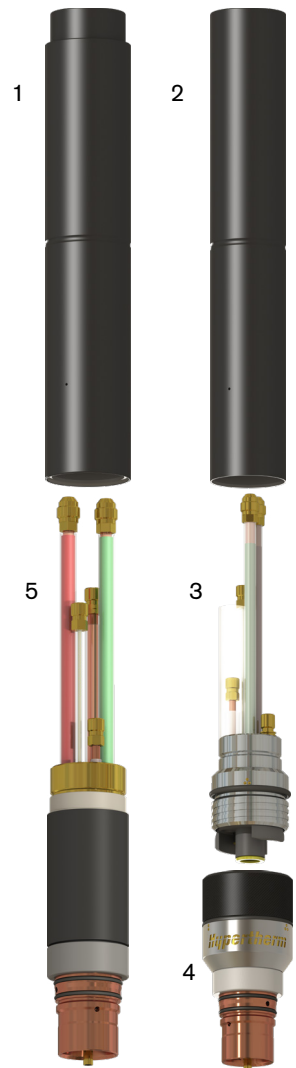

Standard leads – RHF

Part number	Lead length
028657	3 m (10')
028658	4.6 m (15')
028659	6.1 m (20')
028546	7.6 m (25')
028660	9.2 m (30')
028661	10.6 m (35')
028662	12.2 m (40')
028663	13.7 m (45')
028547	15.3 m (50')
028767	16.8 m (55')
028768	18.3 m (60')

Standard leads – LHF

Part number	Lead length
028657	3 m (10')
028658	4.6 m (15')
028659	6.1 m (20')
028546	7.6 m (25')
028660	9.2 m (30')
028661	10.6 m (35')
028662	12.2 m (40')
028663	13.7 m (45')

Mounting sleeves

	Part number	Length	Diameter
1	220943	279.4 mm (11")	50.8 mm (2")
2	220942	279.4 mm (11")	44.45 mm (1.75")

Torch options

	Part number	Length	Diameter
3	220913	Quick-disconnect receptacle	
4	220921	HyPro2000 Quick-disconnect torch	
5	220961	HyPro2000 straight-torch for punch presses	

Additional parts available (not shown)

Part number	Description
228557	Machine torch (Quick-disconnect torch, set of 200 A consumables)
228571	Chip upgrade (includes 2 chips)
027338	Chip removal tool
104119	Consumables removal tool
027055	Silicone lubricant for o-rings
02882	Torch coolant – Cool solution: 70/30 PG 1-gal.
129840	*HT2000 off-valve assembly – LHF

*129840 is required on LHF systems, if not already installed.
See page 58 to learn about the value of preventive maintenance.

HT2000® standard and HySpeed consumables

HySpeed® technology utilizes Coaxial-assist jet technology to boost cutting speeds as much as 50% over conventional designs.



Technologies

Chambered swirl ring

Coaxial-assist™ jet

Dimpled electrode

HyDefinition®

HyLife®

Hyspeed®

LongLife®

SilverPlus®

Mild steel consumables

Plasma gas	Amperage	Process	Shield	Retaining cap*	Nozzle	Swirl ring	Electrode	SilverPlus	Water tube
Air	100 A		020448	120837	020611	020607	120547	----	020963
	200 A	Gouging	020485	120837	020615	020607	120667	----	020963
	200 A		020424	120837	020608	020679	120667	----	020963
N ₂	200 A		020424	120837	020608	020607	020415	----	020963
O ₂	50 A		120186	120185	120182	120179	120178	----	020963
	100 A		020424	120837	020690	020613	120547	----	020963
Hyspeed®	100 A	CCW	020424	120838	020690	120252	120547	----	020963
	200 A		020424	120837	020605	120833	120667	220084	020963
LongLife®	200 A	CCW	020424	120838	020605	120834	120667	220084	020963
	200 A	HySpeed	220239	220242	220237	220236	220235	----	020963
SilverPlus®	200 A	HySpeed CCW	220239	220243	220237	220244	220235	----	020963
	200 A	Bevel	120260	120837	120259	120833	120258	----	120257
	200 A	Bevel CCW	120260	120838	120259	120834	120258	----	020963



Stainless steel/aluminum consumables

Plasma gas	Amperage	Process	Shield	Retaining cap*	Nozzle	Swirl ring	Electrode	Water tube
Air	40 A		020688	020423	020689	020613	120667	020963
	100 A		020488	120837	020611	020607	120547	020963
	200 A		020424	120837	020608	020679	120667	020963
H35	100 A		020448	120837	020611	020607	020415	020963
	200 A		020602	120837	020608	020607	020415	020963
	200 A	Gouging	020485	120837	020615	020607	020415	020963
N ₂	200 A		020424	120837	020608	020607	020415	020963



Water muffler consumables**

Plasma gas	Amperage	Process	Shield	Retaining cap*	Nozzle	Swirl ring	Electrode	Water tube
Air	100 A		020618	020423	020611	020607	120547	020963
	200 A		020566	020423	020608	020679	120667	020963
N ₂	200 A		020566	020423	020608	020607	020415	020963
O ₂	100 A		020566	020423	020690	020613	120547	020963
	200 A		020566	020423	020605	120833	120667	020963
	200 A	HySpeed	220295	220238	220237	220236	220235	020963

* If the Command THC or other ohmic contact sensing device is NOT in use, retaining caps with no IHS tab: 020423 clockwise; 020955 counter-clockwise can be used for all cutting currents except 50A; 120185 for 50A cutting only. For HySpeed 200A O₂ cutting only; Use retaining 220238 clockwise and 220241 counter-clockwise. Use retaining cap 220238 for clockwise.

** Do not use the water muffler when cutting with H35.

HT2000® torch assembly options



Standard leads

Part number	Lead length
028657	3 m (10')
028658	4.5 m (15')
028659	6 m (20')
028546	7.5 m (25')
028660	9 m (30')
028661	10 m (35')
028662	12 m (40')
028663	14 m (45')
028547	15 m (50')

Mounting sleeves

	Part number	Description	Length	Diameter
1	120894	2" Sleeve	273 mm (10.75")	50.8 mm (2")
2	020431	1.75" Sleeve	273 mm (10.75")	44.5 mm (1.75")
	020041	Stainless steel	298 mm (11.75")	50.8 mm (2")

Torch options

	Part number	Description
3	120584	Standard
	120356	Stainless steel body

Additional parts available (not shown)

Part number	Description
128824	HySpeed consumable kit
128907	Preventive maintenance kit (torch main body, coolant, light bulb, contactor, relay)
128381	Standard machine torch (torch, receptacle, sleeve, consumables, valve)
128367	Stainless steel machine torch (torch, receptacle, sleeve, consumables, valve)
128255	Standard machine torch – LHF (torch, receptacle, sleeve, consumables, valve)
128369	Stainless steel machine torch – LHF (torch, receptacle, sleeve, consumables, valve)
129470	HT2000 off-valve assembly (when using 2" sleeve)
129168	HT2000 off-valve assembly (when using 1.75" sleeve)
006100	Solenoid valve (120# 1/8" FPT)
024355	Hose (Off-valve to torch main body, 1')
024550	Hose – LHF (Off-valve to torch main body)
020407	Adapter (1.75" – 2" torch mounting sleeve)
120832	Valve mounting bracket (when using 2" sleeve)
120492	Valve mounting bracket (when using 1.75" sleeve)
220311	Valve mounting bracket – LHF (when using 2" sleeve)
044027	O-ring (torch)
027055	Silicone lubricant for o-rings
028872	Torch coolant – Cool solution: 70/30 PG, 1-gal.
802070	HySpeed HT2000 plasma arc cutting system instruction manual

See page 58 to learn about the value of preventive maintenance.

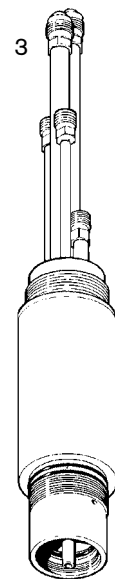
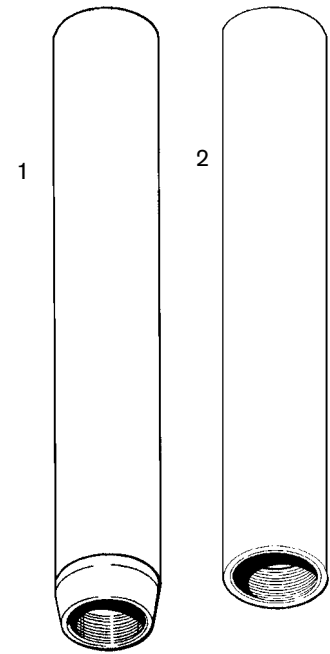

HSD130[®] consumables – machine

Technologies

Chambered swirl ring

HyLife[®]

TrueFlow[™]

Tool free

Tool free nozzle

SilverPlus[®]



Mild steel consumables

	Amperage	Shield	Retaining cap	Nozzle	Swirl ring	Electrode	SilverPlus electrode	Water tube
O ₂	50 A	220532	220578	220530	220529	220528	-----	220521
			220490 without tab				-----	
130 A		220491	220578	220489	220488	220487	420185	220521
			220490 without tab					



Mild steel/stainless steel/aluminum consumables

	Amperage	Shield	Retaining cap	Nozzle	Swirl ring	Electrode	Water tube
Air	45 A	220532	220578	220525	220529	220528	220521
			220490 without tab				
130 A		220536	220578	220492	220488	220487	220521
			220490 without tab				



Stainless steel consumables

	Amperage	Shield	Retaining cap	Nozzle	Swirl ring	Electrode	Water tube
N ₂	45 A	220532	220534	220525	220529	220528	220521
			220533 without tab				
130 A		220536	220578	220535	220488	020415	220521
			220490 without tab				



Stainless steel/aluminum consumables

	Amperage	Shield	Retaining cap	Nozzle	Swirl ring	Electrode	Water tube
H35	130 A	220536	220534	220535	220529	020415	220521
			220533 without tab				



HSD130® torch assembly options



Standard leads

Part number	Lead length
228050	7.5 m (25')
228051	15 m (50')

Mounting sleeve

	Part number	Description	Length	Diameter
1	220473	Standard	228 mm (9")	44.45 mm (1.75")

Torch

	Part number	Description
2	220474	Standard

Additional parts available (not shown)

Part number	Description
228144	HSD machine torch assembly (torch, sleeve, 130 A O ₂ consumables)
228146	Consumables starter kit (mild steel)
228156	Consumables starter kit (stainless steel, aluminum)
027055	Silicone lubricant for o-rings
004630	Electrode pit depth gauge
027102	Electrode removal tool
028872	Torch coolant – Cool solution: 70/30 PG, 1-gal.
805450	HySpeed HSD130 LHF instruction manual

See page 58 to learn about the value of preventive maintenance.



HyPerformance® HD4070® consumables

For HD4070 systems that have been upgraded with the HyPerformance torch



Mild steel consumables

- Technologies
- Chambered swirl ring
- Conical Flow™
- Dimpled electrode
- HyDefinition®
- HyLife®
- LongLife®
- Quick disconnect
- SilverPlus®
- TrueFlow™

Amperage	Shield cap	Shield	Nozzle retaining cap	Nozzle	Swirl ring	Electrode	SilverPlus	Water tube
30 A	220173	220194	220313	220193	220180	220192	-----	220340
50 A	220173	220555	220313	220554	220553	220552	-----	220340
80 A	220173	220189	220176	220188	220179	220187	420566	220340
130 A	220173	220183	220176	220182	220179	220181	220665	220340
200 A	220398	220356	220355	220354	220353	220352	220666	220340



Stainless steel consumables

Amperage	Shield cap	Shield	Nozzle retaining cap	Nozzle	Swirl ring	Electrode	Water tube
45 A	220173	220202	220304	220201	220180	220308	220340
80 A	220173	220338	220304	220337	220179	220339	220340
130 A	220173	220198	220304	220197	220179	220307	220340
200 A	220398	220345	220344	220343	220342	220307	220340



Aluminum consumables

Amperage	Shield cap	Shield	Nozzle retaining cap	Nozzle	Swirl ring	Electrode	Water tube
45 A	220173	220202	220176	220201	220180	220308	220340
130 A	220173	220198	220304	220197	220179	220307	220340
200 A	220398	220345	220347	220346	220342	220307	220340



HyPerformance® HD4070® torch assembly options



Standard leads

	Part number	Lead length
1	128890	1.8 m (6')

Mounting sleeves

	Part number	Description	Length	Diameter
2	220232	Standard	199 mm (7.8")	50.8 mm (2")
	220516	Extended	283 mm (11")	50.8 mm (2")

Quick-disconnect receptacle

	Part number	Description
3	220163	Standard
	220573	Bevel (includes sleeve)

HyPerformance quick-disconnect torch

	Part number	Description
4	220162	Standard (used in all applications)

Additional parts available (not shown)

Part number	Description
228048	Machine torch (Torch, receptacle, extended sleeve, 130 A MS consumables)
128879	Torch rebuild kit
128880	Quick-disconnect kit (O-ring and connector)
104269	2" spanner wrench
004630	Electrode pit depth gauge
104119	Consumables removal tool
027055	Silicone lubricant for o-rings
028872	Torch coolant – Cool solution: 70/30 PG, 1-gal.
804900	HyPerformance HD4070 plasma system instruction manual

See page 58 to learn about the value of preventive maintenance.

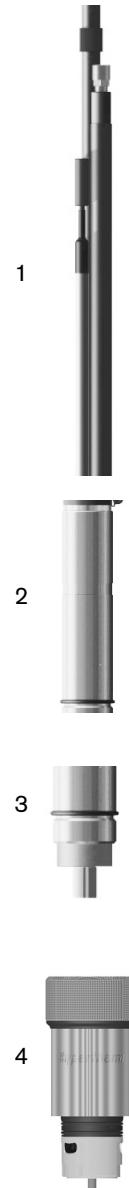

HyDefinition® HD4070® consumables

Technologies

Chambered
swirl ring

HyLife®

Vented shield



Mild steel consumables

Amperage	Shield cap*	Nozzle	Swirl ring	Electrode	Water tube
70 A	120786	120685	120684	120683	120025
100 A	120786	120660	120655	120654	120025
200 A	120786	120692	120691	120690	120025



Stainless steel consumables

Amperage	Shield cap*	Nozzle	Swirl ring	Electrode	Water tube
70 A	120786	120713	120712	120711	120025
200 A	120786	120727	120726	120725	120025



Aluminum consumables

Amperage	Shield cap*	Nozzle	Swirl ring	Electrode	Water tube
70 A	120786	120748	120747	120746	120025
200 A	120786	120762	120761	120760	120025



Marking consumables

Amperage	Shield cap*	Nozzle	Swirl ring	Electrode	Water tube
	120786	120671	120670	120669	120025

*120907 with IHS tab



HyDefinition® HD4070® torch assembly options



Torch assembly

Part number	Description
128500	Torch with 6' (2 m) leads

Quick-disconnect torch main body

Part number	Description
120651	Standard



Additional parts available (not shown)

Part number	Description
004147	Electrode pit depth gauge
027102	Electrode removal tool
004663	Consumables removal tool
027347	Water tube replacement tool
027055	Silicone lubricant for o-rings
028872	Torch coolant – Cool solution: 70/30 PG, 1-gal.
803760	HyDefinition HD4070 plasma arc cutting/marking system instruction manual

See page 58 to learn about the value of preventive maintenance.

HyPerformance® HD3070® consumables

For HD3070 systems that have been upgraded with the HyPerformance torch

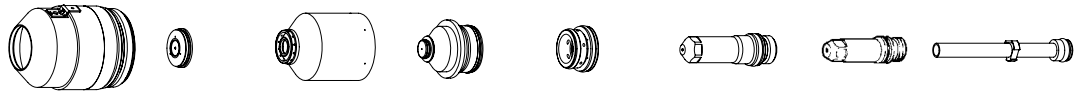

Technologies

Chambered swirl ring

Conical Flow™

Dimpled electrode

HyDefinition®

HyLife®

LongLife®

Quick disconnect

SilverPlus®

TrueFlow™

Mild steel consumables

Amperage	Shield cap	Shield	Nozzle retaining cap	Nozzle	Swirl ring	Electrode	SilverPlus	Water tube
30 A	220173	220194	220313	220193	220180	220192	----	220340
50 A	220173	220555	220313	220554	220553	220552	----	220340
80 A	220173	220189	220176	220188	220179	220187	420566	220340
100 A	220173	220183	220176	220510	220179	220181	----	220340

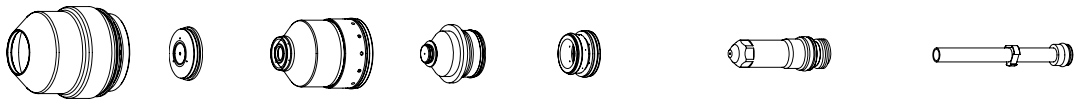

Stainless steel consumables

Amperage	Shield cap	Shield	Nozzle retaining cap	Nozzle	Swirl ring	Electrode		Water tube
45 A	220173	220202	220304	220201	220180	220308		220340
70 A	220173	220189	220176	220188	220179	220187		220340
80 A	220173	220338	220304	220337	220179	220339		220340
100 A	220173	220627	220644	220626	220640	220641		220340

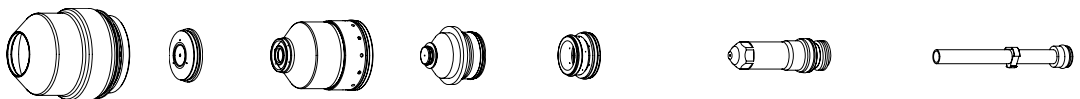

Aluminum consumables

Amperage	Shield cap	Shield	Nozzle retaining cap	Nozzle	Swirl ring	Electrode		Water tube
45 A	220173	220202	220176	220201	220180	220308		220340
70 A	220173	220198	220176	220188	220179	220187		220340
100 A	220173	220627	220644	220626	220640	220641		220340



HyPerformance® HD3070® torch assembly options



Leads (with blow back option)

	Part number	Lead length
1	028866	4.5 m (15')
	028867	6 m (20')
	028868	7.5 m (25')
	028869	9 m (30')
	028870	12 m (40')
	128001	15 m (50')
	128083	23 m (75')
	128084	30 m (100')

Leads (without blow back option)

Part number	Lead length
028498	4.5 m (15')
028499	6 m (20')
028500	7.5 m (25')
028501	9 m (30')
028502	10 m (35')
028503	12 m (40')
128132	15 m (50')
128133	23 m (75')
128134	30 m (100')

Mounting sleeve

	Part number	Description	Length	Diameter
2	220624	Standard	254 mm (10")	50.8 mm (2")

Quick-disconnect receptacle

	Part number	Description
3	220163	Standard
	220573	Bevel (includes sleeve)

HyPerformance quick-disconnect torch

	Part number	Description
4	220162	Standard (used in all applications)

Additional parts available (not shown)

Part number	Description
805390	Field Service Bulletin
228168	Preventive maintenance kit (Machine torch, coolant, filter, coil, relay, o-rings, water tube)
128879	Torch rebuild kit
128880	Quick-disconnect kit (O-ring and connector)
104269	2" spanner wrench
004630	Electrode pit depth gauge
104119	Consumables removal tool
027055	Silicone lubricant for o-rings
028872	Torch coolant - Cool solution: 70/30 PG, 1-gal.

See page 58 to learn about the value of preventive maintenance.



HyDefinition® HD3070® consumables for PAC184 and PAC186 torches

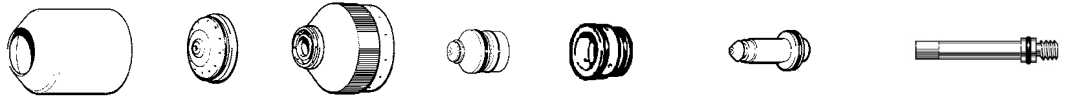

Mild steel consumables for PAC184 torch

Amperage	Shield cap*	Shield	Nozzle retaining cap	Nozzle	Swirl ring	Electrode	Water tube
30 A	120221	120222	120219	120218	120212	120209	120377
30 A with IHS tab	120543	120222	120219	120218	120212	120209	120377

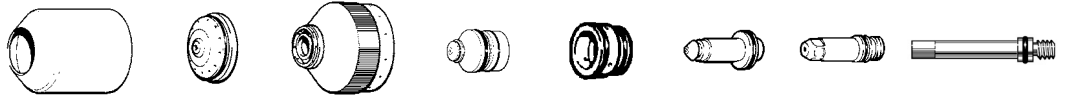

Mild steel consumables for PAC186 for torch

Amperage	Shield cap*	Shield	Nozzle retaining cap	Nozzle	Swirl ring	Electrode	SilverPlus	Water tube
15 A	020634	-----	020633	-----	020637	120111	-----	120377
30 A	020634	020671	020633	020645	020637	120111	-----	120377
50 A	020634	020671	020633	020646	020637	120112	-----	120377
70 A	020634	020796	020795	020647	020789	120112	-----	120377
100 A	020634	120273	120266	120272	020637	120410	-----	120377
100 A	020634	220508	020795	220409	020637	-----	220408	120377



Stainless steel consumables for PAC186 for torch

Amperage	Shield cap*	Shield	Nozzle retaining cap	Nozzle	Swirl ring	Electrode	Water tube
30 A	020634	020941	020940	020938	020937	120113	120377
50 A	020634	020949	020795	020948	020947	120113	120377
70 A	020634	020796	020795	020647	020789	120112	120377
100 A	020634	120594	120592	120591	120590	120589	120377

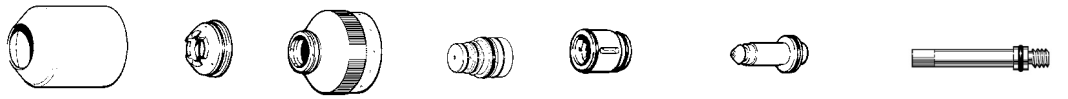

Aluminum consumables for PAC186 for torch

Amperage	Shield cap*	Shield	Nozzle retaining cap	Nozzle	Swirl ring	Electrode	Water tube
70 A	020634	020796	020795	020647	020789	120112	120377

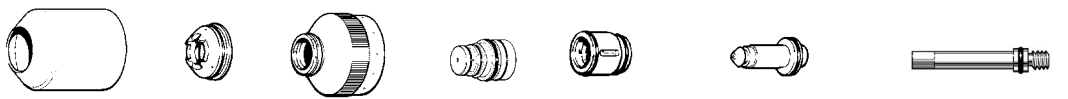

Copper consumables for PAC186 for torch

Amperage	Shield cap*	Shield	Nozzle retaining cap	Nozzle	Swirl ring	Electrode	Water tube
50 A	020634	020949	020795	020948	020947	120113	120377
70 A	020634	020796	020795	020647	020789	120112	120377

*020687 with IHS tab

Technologies

Chambered swirl ring

HyLife®

SilverPlus®

Vented shield



HyDefinition® HD3070® torch assembly options



PAC186 torch

Leads

Part number	Lead length
028868	7.5 m (25')

Mounting sleeves and receptacles

	Part number	Description
1	020668	PAC186 sleeve
2	028855	Straight quick disconnect

Torch options

	Part number	Description
3	120208	PAC184, torch
4	120349	PAC186, torch

Additional parts available (not shown)

Part number	Description
129282	Off-valve assembly (with blow back solenoid)
027055	Silicone lubricant for o-rings
028872	Torch coolant – Cool solution: 70/30 PG, 1-gal.
228000	HD3070 SilverPlus consumable starter kit
802180	HyDefinition HD3070 plasma arc cutting system w/automatic gas console instruction manual
802170	HyDefinition HD3070 plasma arc cutting system w/manual gas console instruction manual

See page 58 to learn about the value of preventive maintenance.

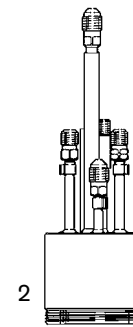
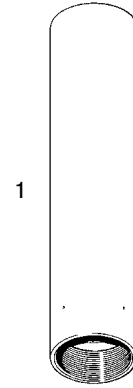

HySpeed® HT4400® consumables

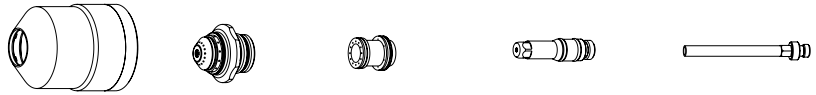

Technologies

Chambered swirl ring

CoolCore™

HyLife®

LongLife®

Quick disconnect

SilverPlus®

Mild steel consumables

Plasma gas	Amperage	Process	Retaining cap*	Nozzle	Swirl ring	Electrode	SilverPlus	Water tube
O ₂	100 A		120786	120777	120783	120785	----	120025
	200 A		120786	120787	120791	120793	220412	120025
	200 A	CCW	120786	120788	120792	120793	220412	120025
	300 A		120786	120794	120913	120802	220412	120025
	300 A	CCW	120786	120795	120914	120802	220412	120025
	400 A		120786	120934	120939	120810	220412	120025
	400 A	CCW	120786	120935	120940	120810	220412	120025
	400 A	Bevel	120786	120934	120939	120810	220412	120025
	400 A	Bevel CCW	120786	120935	120940	120810	220412	120025

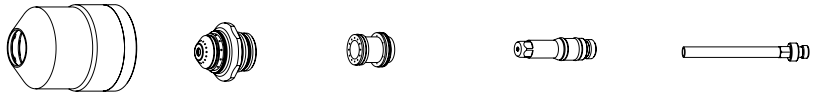

Stainless steel/aluminum consumables

Plasma gas	Amperage	Process	Retaining cap*	Nozzle	Swirl ring	Electrode	Water tube
N ₂	200 A		120786	120794	120853	120855	120025
	200 A	CCW	120786	120795	120854	120855	120025
	400 A		120786	120856	120853	120855	120025
	400 A	CCW	120786	120857	120854	120855	120025

* Retaining cap with IHS Tab 120907, retaining cap for underwater cutting 120984

SilverPlus electrode technology can deliver up to twice the consumable life for the HT4400.

Contact your Hypertherm channel partner to arrange a demonstration



HySpeed® HT4400® torch assembly options



Standard leads

Part number	Lead length
128482	HT4400 Torch leads 5'
128483	HT4400 Torch leads 10'
128484	HT4400 Torch leads 15'
128485	HT4400 Torch leads 20'
128486	HT4400 Torch leads 25'
128487	HT4400 Torch leads 30'
128488	HT4400 Torch leads 40'
128489	HT4400 Torch leads 50'
128518	HT4400 Torch leads 60'
228060	HT4400 Bevel torch leads 10' w/72" gas
228064	HT4400 Bevel torch leads 10' w/96" gas
228058	HT4400 Bevel torch leads 15' w/72" gas
228059	HT4400 Bevel torch leads 15' w/96" gas

Quick-disconnect torch assembly options

Part number	Description
128342	Torch with 15' leads with 400 A mild steel consumables
128431	Torch with 10' leads with 400 A mild steel consumables
128430	Torch with 6' leads with 400 A mild steel consumables

Quick-disconnect torch options

	Part number	Description
1	120651	Quick-disconnect torch
	120775	Quick-disconnect receptacle
	220572	Bevel quick-disconnect receptacle

Additional parts available (not shown)

Part number	Description
228011	Preventive maintenance kit
004663	Nozzle wrench
004630	Electrode pit depth gauge
027012	Silicone lubricant for o-rings
027102	Electrode wrench
027347	Water tube replacement tool
128654	Bullet connector replacement kit
044028	O-ring
028872	Torch coolant - Cool solution: 70/30 PG, 1-gal.
803580	HySpeed HT4400 plasma arc cutting system instruction manual

See page 58 to learn about the value of preventive maintenance.

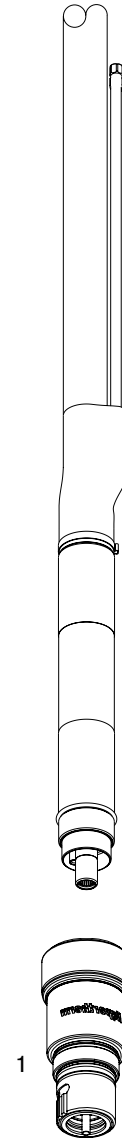

HT4001[®] consumables

Technologies

Chambered swirl ring

LongLife[®]

SilverPlus[®]



Mild steel consumables – without H401/H601

Plasma gas	Amperage	Process	Retaining cap*	Nozzle	Swirl ring	Electrode	SilverPlus	Water tube
O ₂	260 A		020579	020086	020623	020663	220397	020990
	340 A		020579	020086	120135	120630	----	020990
	260 A	Bevel	120390	120384	020623	020975	----	020992
	340 A	Bevel	120390	120384	120460	120836	----	020992



Mild steel/stainless steel/aluminum consumables – without H401/H601

Plasma gas	Amperage	Process	Retaining cap*	Nozzle	Swirl ring	Electrode	Water tube
N ₂	260 A		020579	020089	020039	020082	020990
	400 A		020579	020084	020039	020082	020990
	260 A	Bevel	120390	120386	020039	020968	020991
	400 A	Bevel	120390	120387	020039	020968	020991



Mild steel /stainless steel/aluminum consumables – with H401/H601

Plasma gas	Amperage	Process	Retaining cap*	Nozzle	Swirl ring	Electrode	Water tube
N ₂	260 A		020580	020281	020039	020285	020990
	400 A		020580	020282	020039	020285	020990
	600 A		020580	020283	020039	020285	020990
	760 A		020580	020284	020040	020285	020990
	260 A	Bevel	120390	120386	020039	020968	020991
	400 A	Bevel	120390	120387	020039	020968	020991
	600 A	Bevel	120390	120388	020039	020968	020991
	700 A	Bevel	120390	120389	020040	020968	020991

*CE countries must use CE retaining cap (please refer to operators manual for more information and part numbers)

HT4001[®] torch assembly options

Standard leads

	Part number	Lead length
1	028508	3 m (10')
	028511	7.6 m (25')
	028512	9.2 m (30')
	028513	10.7 m (35')
	028514	12.2 m (40')
	028515	13.7 m (45')
	028509	15 m (50')
	028516	15.3 m (50')
	028770	16.8 m (55')
	028771	18.3 m (60')
	028510	20 m (65')

Mounting sleeves

	Part number	Description
2	020668	PAC186 sleeve

Torch

	Part number	Description
3	020328	Standard
	020970	Bevel

Additional parts available (not shown)

Part number	Description
020046	Torch mounting bracket
028741	Machine torch - Bevel (torch, sleeve, consumables)
028507	Machine torch - Standard (torch, sleeve, consumables)
004147	Electrode gauge
027055	Silicone lubricant for o-rings
027347	Water tube replacement tool
004732	Cap removal tool
025028	O-ring kit
028872	Torch coolant - Cool solution: 70/30 PG, 1-gal.
802000	HT4001 plasma arc cutting system instruction manual

See page 58 to learn about the value of preventive maintenance.

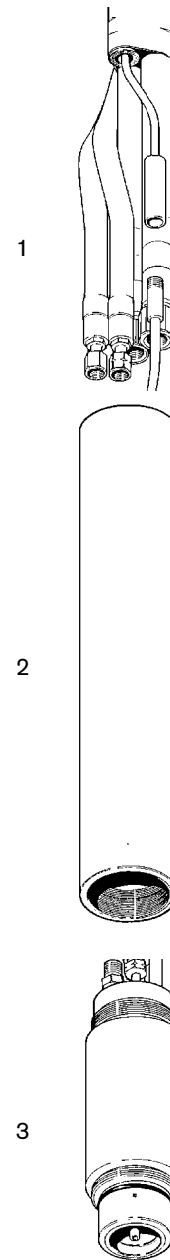

HT4000® consumables and torch assembly options

Technologies
SilverPlus®



Mild steel consumables

Plasma gas	Amperage	Retaining cap	Nozzle	Swirl ring	Electrode	SilverPlus	Water tube
O ₂	260 A	020579	020086 (.099)	020623	020663	220397	020990
N ₂	260 A	020579	020089 (.120)	020039	020082	-----	020990
	380 A	020579	020084 (.166)	020039	020082	-----	020990
	400 A	020579	020084 (.166)	020039	020082	-----	020990

Stainless steel consumables

Plasma gas	Amperage	Retaining cap	Nozzle	Swirl ring	Electrode	Water tube
N ₂	260 A	020579	020089 (.120)	020039	020082	020990
	380 A	020579	020084 (.166)	020039	020082	020990
	400 A	020579	020084 (.166)	020039	020082	020990

Aluminum consumables

Plasma gas	Amperage	Retaining cap	Nozzle	Swirl ring	Electrode	Water tube
N ₂	250 A	020579	020089 (.120)	020039	020082	020990
	260 A	020579	020089 (.120)	020039	020082	020990
	360 A	020579	020084 (.166)	020039	020082	020990
	380 A	020579	020084 (.166)	020039	020082	020990
	400 A	020579	020084 (.166)	020039	020082	020990

Standard leads

Part number	Lead length
028508	3 m (10')
028509	4.5 m (15')
028510	6 m (20')
028511	7.6 m (25')
028512	9.2 m (30')
028513	10.7 m (35')
028514	12.2 m (40')
028515	13.7 m (45')
028516	15 m (50')

Additional parts available (not shown)

Part number	Description
020046	Torch mounting bracket
004147	Electrode guage
027055	Silicone lubricant for o-rings
027347	Water tube replacement tool
027001	Electrode wrench
025028	O-ring kit
028507	Machine torch (torch, sleeve, consumables)
028872	Torch coolant – Cool solution: 70/30 PG, 1-gal.
801480	HT4000 plasma arc cutting system instruction manual

See page 58 to learn about the value of preventive maintenance.

Mounting sleeves

Part number	Description
020041	Standard
029044	IHS system sleeve

Torch options

Part number	Description
020328	Standard
020970	Bevel

HT400® consumables and torch assembly options

Technologies
SilverPlus®



Mild steel consumables

Plasma gas	Amperage	Retaining cap	Nozzle	Swirl ring	Electrode	SilverPlus	Water tube
O ₂	260 A	020579	020086 (.099)	020096	020081	220397	020990
N ₂	260 A	020579	020089 (.120)	020039	020082	-----	020990
	380 A	020579	020084 (.166)	020039	020082	-----	020990
	400 A	020579	020084 (.166)	020039	020082	-----	020990

Stainless steel consumables

Plasma gas	Amperage	Retaining cap	Nozzle	Swirl ring	Electrode	Water tube
N ₂	260 A	020579	020089 (.120)	020039	020082	020990
	380 A	020579	020084 (.166)	020039	020082	020990
	400 A	020579	020084 (.166)	020039	020082	020990

Aluminum consumables

Plasma gas	Amperage	Retaining cap	Nozzle	Swirl ring	Electrode	Water tube
N ₂	250 A	020579	020089 (.120)	020039	020082	020990
	260 A	020579	020089 (.120)	020039	020082	020990
	360 A	020579	020084 (.166)	020039	020082	020990
	380 A	020579	020084 (.166)	020039	020082	020990
	400 A	020579	020084 (.166)	020039	020082	020990

Standard leads

Part number	Lead length
028143	12.2 m (40')

Mounting sleeve

Part number	Description
020041	Standard

Torch options

Part number	Description
020080	Standard

Additional parts available (not shown)

Part number	Description
004147	Electrode guage
027055	Silicone lubricant for o-rings
027347	Water tube replacement tool
027001	Electrode wrench
028229	Machine torch assembly (torch, sleeve, consumables)
800540	HT400 plasma arc cutting system instruction manual
028872	Torch coolant – Cool solution: 70/30 PG, 1-gal.

See page 58 to learn about the value of preventive maintenance.

PAC500™ consumables and torch assembly options



Mild steel/stainless steel/aluminum consumables

Plasma gas	Amperage	Retaining cap*	Nozzle	Swirl ring	Electrode	Water tube
N ₂	Up to 260 A	020034 (Tapered)	020050 (.120)	020039	020038	120035
		020043 (Flared)				
	Up to 400 A	020034 (Tapered)	020035 (.166)	020039	020038	120035
		020043 (Flared)				
	Up to 600 A	020034 (Tapered)	020036 (.187)	020039	020038	120035
	Up to 750 A	020034 (Tapered)	020037 (.220)	020040	020038	120035

Stainless steel/aluminum consumables

Plasma gas	Amperage	Retaining cap	Nozzle	Swirl ring	Electrode	Water tube
N ₂	Up to 1000 A	020034 (Tapered)	020047 (.250)	020048	020038	120035

*For application information please reference 800370 PAC500 Water injection plasma cutting system instruction manual

Standard leads

Part number	Lead length
028143	12.2 m (40')

Mounting sleeve

Part number	Description
020041	Standard

Torch

Part number	Description
020030	Standard

Additional parts available (not shown)

Part number	Description
004147	Electrode gauge
027055	Silicone lubricant for o-rings
027347	Water tube replacement tool
027001	Electrode wrench
028160	Machine torch assembly w/tapered cap - (torch, sleeve, consumables) up to 400 A
025028	O-ring kit
028872	Torch coolant - Cool solution: 70/30 PG, 1-gal.
800370	PAC500 Water injection plasma cutting system instruction manual

See page 58 to learn about the value of preventive maintenance.

Additional mirror-image cutting (CCW) consumables available

XPR™

Amperage	Process	Shield cap	Shield	Nozzle cap	Nozzle	Swirl ring	Electrode	Water tube
Mild steel								
30 A	O ₂ /O ₂	420200	420619	420365	420225	420620	420222	420368
80 A	O ₂ /Air	420200	420605	420365	420243	420607	420240	420368
130 A	O ₂ /Air	420200	420608	420365	420252	420607	420249	420368
170 A	O ₂ /Air	420200	420616	420365	420261	420609	420258	420368
300 A	O ₂ /Air	420200	420615	420365	420279	420594	420276	420368
Non-ferrous								
40 A	N ₂ /N ₂	420200	420624	420365	420288	420598	420303	420368
	Air/Air	420200	420624	420365	420288	420598	420294	420368
60 A	N ₂ /N ₂ and F5/N ₂	420200	420603	420365	420297	420604	420303	420368
	N ₂ /H ₂ O	420200	420593	420365	420296	420604	420303	420368
80 A	Air/Air	420200	420309	420365	420297	420604	420294	420368
	N ₂ /N ₂ and F5/N ₂	420200	420603	420365	420306	420604	420303	420368
130 A	N ₂ /H ₂ O	420200	420593	420365	420290	420604	420303	420368
	Air/Air	420200	420309	420365	420306	420604	420294	420368
170 A	N ₂ /N ₂	420200	420597	420365	420315	420598	420356	420368
	H ₂ -Ar-N ₂ /N ₂	420200	420597	420365	420315	420604	420356	420368
	N ₂ /H ₂ O	420200	420595	420365	420315	420598	420356	420368
300 A	N ₂ /N ₂	420200	420613	420365	420324	420598	420356	420368
	H ₂ -Ar-N ₂ /N ₂	420200	420613	420365	420324	420604	420356	420368
	N ₂ /H ₂ O	420200	420611	420365	420324	420598	420356	420368
300 A	N ₂ /N ₂	420200	420601	420365	420359	420604	420356	420368
	H ₂ -Ar-N ₂ /N ₂	420200	420601	420365	420359	420623	420356	420368
	N ₂ /H ₂ O	420200	420622	420365	420359	420604	420356	420368

HT4001®

Amperage	Retaining cap	Nozzle	Swirl ring	Electrode	Water tube
O₂ – Mild steel – without H401/H601					
260 A	020579	020392	120015	020663	020990
340 A	020579	020392	120263	120630	020990
260 A bevel	120390	120385	120015	020975	020992
340 A bevel	120390	120385	120461	120836	020992
N₂ – Mild steel/Stainless/Aluminum – without H401/H601					
260 A	020579	020089	020042	020082	020990
400 A	020579	020084	020042	020082	020990
260 A bevel	120390	120386	020042	020968	020991
400 A bevel	120390	120387	020042	020968	020991
N₂ – Mild steel/Stainless/Aluminum – with H401/H601					
260 A	020580	020281	020042	020285	020990
400 A	020580	020282	020042	020285	020990
600 A	020580	020283	020042	020285	020990
760 A	020580	020284	020079	020285	020990
260 A bevel	120390	120386	020042	020968	020991
400 A bevel	120390	120387	020042	020968	020991
600 A bevel	120390	120388	020042	020968	020991
760 A bevel	120390	120389	020079	020968	020991

HPRXD®

Amperage	Shield cap	Shield	Nozzle cap	Nozzle	Swirl ring	Electrode	Water tube
Mild steel							
30 A	220747	220194	220810	220193	220306	220192	220340
50 A	220747	220555	220810	220554	220549	220552	220340
80 A	220747	220189	220755	220188	220305	220187	220340
130 A	220747	220183	220755	220182	220305	220181	220340
200 A	220637	220761	220811	220354	220350	220352	220340
260 A	220637	220764	220812	220439	220442	220435	220340
400 A	220637	220636	220783	220632	220782	220629	220571
80 A bevel	220637	220742	220996	220806	220305	220802	220700
130 A bevel	220637	220742	220794	220646	220305	220649	220700
260 A bevel	220637	220741	220794	220542	220442	220541	220571
400 A bevel	220637	220636	220783	220632	220782	220629	220571
Non-ferrous							
45 A	220747	220202	220756	220201	220306	220308	220340
60 A	220747	220815	420337	220847	220306	220339	220340
80 A	220747	220338	220756	220337	220305	220339	220340
			220755 (H35)	220197	220305	220307	220340
130 A	220747	220198	220755 (N ₂)				220340
			220755 (N ₂)				220340
200 A	220637	220762	420335	220343	420334	220307	220340
260 A	220637	220763	420335	220406	420330	220307	220340
400 A	220637	220707	220885	220708	420330	220709	220571
600 A	220637	220707	220783 (H35)	220859	220350 (H35)	220709	220571
			220712 (N ₂)		420330 (N ₂)		
800 A up to 100 mm	220637	220886	220712	220884	220350	220882	220881
800 A thicker than 100 mm			220885		220353		
130 A bevel	220637	220738	420336	220656	220305	220606	220571
260 A bevel	220637	220738	420336	220607	420330	220606	220571
400 A bevel	220637	220707	220885	220708	420330	220709	220571
600 A bevel	220637	220707	220783 (H35)	220859	220350 (H35)	220709	220571
			220712 (N ₂)		420330 (N ₂)		
800 A bevel up to 100 mm	220637	220886	220712	220884	220350	220882	220881
800 A bevel thicker than 100 mm			220885		220353		

HD3070®

Amperage	Process	Shield cap	Shield	Nozzle cap	Nozzle	Swirl ring	Electrode	Water tube
30 A	Mild steel	020634	020671	120623	020645	120626	120111	120377
30 A	Stainless steel	020634	020941	120622	020938	120625	120113	120377
50 A	Mild steel	020634	020671	120623	020646	120626	120112	120377
50 A	Stainless steel/ Copper	020634	020949	020795	120617	120624	120113	120377
70 A	Mild steel/ Stainless steel/ Aluminum/ Copper	020634	020796	020795	120238	120237	120112	120377
100 A	Mild steel	020634	120273	120621	120272	120626	120410	120377

Value of preventive maintenance and proper torch and consumable use

You wouldn't expect your car to operate at peak efficiency if you never changed the oil or rotated the tires. And you shouldn't expect your Hypertherm plasma system to operate at peak efficiency without regular preventive maintenance.

Key advantages

Hypertherm Preventive Maintenance

Your Hypertherm plasma system is a precision machine with moving parts that require regular service. By performing regular preventive maintenance, you can extend the life of consumable parts, reduce down time, optimize performance and minimize operating costs.

Effective preventive maintenance involves an ongoing process of daily, weekly, monthly and annual checks. It's a simple fact that high stress or moving parts like torches, main contactors, relays and coolant require change-outs. Replace them on your schedule and get the most out of your mechanized system.

Plan for preventive maintenance in advance and experience the benefits

- Reduce downtime to lower the overall cost of cutting metal
- Extend consumable life, optimize performance through regular system "tune-ups"
- Ensure optimal operation; increase output and cut quality
- Cut unplanned repairs; execute scheduled maintenance on an "off shift"
- Eliminate costly labor for emergency repairs; keep things running smoothly
- Avoid expensive expedited shipping charges; buy parts on a schedule
- Rule out "added component" costs where simple failures lead to big problems

All the preventive maintenance tools you need are close at hand – reference the preventive maintenance kit section on page(s) 60–61, and order the kit that is right for your system today!

Consumable care

The performance and life of your consumables are directly related to how well you care for them. In general, all consumables should be free from dirt and other particles.

When assembling a torch make sure all o-rings on the torch and consumables are lubricated properly. Lubricating o-rings extends o-ring life and makes installing consumables easier.



The proper amount of grease will leave the o-ring "shiny", but leave no excess or built up grease. Excess grease will attract contaminants and could cause restrictions in critical passages. Grease may be applied either by finger or using a cotton swab. Always replace o-rings if they have cracks or tears. If you are replacing a water tube remember to lubricate the small o-ring on the base of the water tube.

After you have lubricated all of the torch and consumable o-rings you are ready to start the assembly of your torch.

Using the correct consumables and matching them together appropriately is critical to achieving optimal cutting performance. Proper installation of your consumables involves:

- Using the correct consumable part numbers
- Making sure not to over tighten any parts when assembling them in the torch
- Using o-ring lubricant on consumable and torch o-rings
- Keeping all consumable surfaces clean of dust and dirt

Consumables are specific to amperage, material being cut, and application. It's important to identify the consumable part number. We have laser marked each consumable with its part number for easy identification.

It is a common mistake to use an incorrect mix of consumables or to orient the consumables improperly in the torch. These issues can be eliminated by cross-referencing the laser marked part number with the consumables listed in your Operator Manual that has been provided to you with your Hypertherm system.

Operator Manuals and complete consumables lists by system can be found at Hypertherm.com, either by going to the web page for your plasma system model, or by visiting the Torch and Consumable page. On the website we provide illustrations of consumables and their corresponding part numbers to help you choose the appropriate configuration.

On a daily basis it is important to confirm that you are using:

- The correct consumables
- Proper inlet gas pressures
- Proper gas pressure at the gas consoles
- Sufficient coolant levels (if applicable)

In addition to these daily maintenance routines, we recommend:

- cleaning the power supply
- verifying proper fan operation within the power supply
- verifying that your torch is square to the workpiece
- ensuring that the torch is oriented properly
- inspection of cables and cable connections

Finally, review your operation monthly or semi-monthly through scheduled inspections for your plasma cutting systems.

Evaluation

Examining the metal you will cut can indicate whether or not you are achieving a “good” cut. The height at which you position your torch directly affects the shape of the cut. If the torch is too high, your cuts will have a positive bevel or cut angle. If the torch is too low, your cuts will have a negative bevel or cut angle. A positive angle results when more material is removed from the top of the cut than from the bottom. If more material is removed from the bottom, the cut has a negative angle. When your torch is adjusted properly the bevel angle is minimized.

When cut speed is faster than optimal:

- Bevel angle will increase
- Hardened dross may buildup on the work piece
- The torch height may rise if a torch height control is installed

If these symptoms occur, reduce cutting speed in 2–3% increments until the symptoms are corrected.

When cut speed is slower than optimal:

- Inconsistent edge quality will occur
- Dross may build up on the workpiece
- The torch may dive if a torch height control is installed

Other indicators of correct speed include the angle of the plasma arc exiting out the other side of the cut, and the laglines (vertical cut marks) that appear on the cut edge left behind by the plasma arc.

The sparks exiting out of the cut should trail the cut by about 15°. Trailing at a steeper angle than this indicates cut speed is

too fast. Sparks exiting straight down from the cut with no angle indicates that cutting speed is too slow.

Making small adjustments in torch height and cut speed can make a big difference in your cut quality and in the life of your consumables.

Track

Tracking consumable performance is an important and critical process for improving consumable life and improving the performance of your cutting operation.

Consumable life is driven by many factors, including:

- Cut speeds
- Metal thickness
- Duration of each cut
- Amperage settings

Tracking life lets you determine if the system is performing properly or if an unfavorable adjustment was made to the process.

Track the number of starts and arc-on time for each consumable change to gauge consumable life over time. For true comparisons of one consumable change to another, compare jobs with similarly cut parts of the same thickness with similar cut durations. Hypertherm provides plasma cut data collection sheets to assist you with tracking performance.

Tracking consumable life will allow you to measure how efficiently you are using your consumables so they don't prematurely end up in the scrap bucket.

Preventive maintenance program manuals

Our PM manuals offer a detailed system cleaning, inspection and component replacement schedule, along with helpful maintenance tips. Translations are available in Spanish, Japanese, Chinese (Traditional and Simplified), Korean and Portuguese.

Download at: www.hypertherm.com/en-us/customer-support

Item number	System
809490	XPR
808630	HPR130XD – manual gas
808620	HPR130XD – auto gas
808580	HPR130 – auto gas
808590	HPR130 – manual Gas
808250	HPR260XD – auto gas
808640	HPR260XD – manual gas
808600	HPR260 – auto gas
808610	HPR260 – manual gas
808650	HPR400XD – manual gas
808660	HPR400XD – auto gas
808670	HPR800XD – manual gas
808680	HPR800XD – auto gas
808800	MAXPRO200
809020	HySpeed HT2000
890580	Hypertherm Preventive Maintenance Protocol

Preventive Maintenance kits

For current systems

Page		Torch rebuild kit with filter		Electronics kit with pilot arc relay, contactor, torch main body	
		without coolant	with coolant	XPR300	XPR170
XPR™	200–240 V systems	428639	428640	428641	428878
	380–600 V systems	428639	428640	428642	428879
HyPerformance® plasma XD	HPR800XD® (200–240 V systems)	428263	428264		428270
	HPR800XD® (380–600 V systems)	428263	428264		428272
	HPR400XD® (200–240 V systems)	428263	428264		428270
	HPR400XD® (380–600 V systems)	428263	428264		428272
	HPR260XD® (200–240 V systems)	428263	428264		428269
	HPR260XD® (380–600 V systems)	428263	428264		428272
	HPR130XD®	428263	428264		428268
MAXPRO200®		Quick-disconnect torch rebuild and filter kit		Straight torch rebuild and filter fit	
		without coolant	with coolant	without coolant	with coolant
	MAXPRO200®	428331	428332	428333	428334

Coolant/corrosion inhibitor

Part number	Coolant solution/corrosion inhibitor
428839 NEW!	Coolant solution: 70/30 PG, 55-gal.
028872	Coolant solution: 70/30 PG, 1-gal.
028873	Coolant solution: 100% PG, 1-gal.
128020	Corrosion inhibitor, benzotriazole, 16 oz.

For legacy systems

	Part number	Description	
HySpeed® HSD130®	228167	Annual kit with coolant filter element (2), coolant solution 70/30 (8), main contactor, torch main body, air filter	
		Filter torch rebuild kit	
	without coolant	with coolant	standard contactor
HyPerformance® plasma HPR260® (200–240 V systems)	428309	428310	428266
HyPerformance® plasma HPR260® (380–600 V systems)	428309	428310	428267
HyPerformance® plasma HPR130®	428309	428310	428265
MAX200®	228010	Annual kit with pilot arc relay, main contactor, lens (white), light bulb, coolant filter element (2), coolant solution 70/30 (8), torch main body	
HyPro2000™ for HT2000®	228774	Preventive maintenance kit with HyPro2000 quick disconnect torch main body (220921), for systems that have been upgraded to the HyPro2000 quick disconnect torch main body	
	228911	Preventive maintenance kit with HyPro2000 straight torch main body (220961), for systems that have been upgraded to the HyPro2000 straight torch main body	
HT2000®	228011	Preventive maintenance kit with standard torch main body (120584), for systems that use the standard torch main body	
	228840	Preventive maintenance kit with stainless steel torch main body (120356), for systems that use the stainless steel torch main body	
HPR® HD3070®	228168	Annual kit with pilot arc relay, contactor switch (2), main contactor, lens (red), light bulb, coolant filter element (2), coolant solution 70/30 (8), torch main body, torch kit, quick-disconnect kit	
HySpeed® HT4400®	228011	Annual kit with pilot arc relay, main contactor, lens (white), light bulb, coolant filter element (2), coolant solution 70/30 (8), torch main body	



Hypertherm® technical service

Hypertherm Inc.
 Etna Road, P.O. Box 5010
 Hanover, NH 03755 USA
 603-643-3441 Tel (Main office)
 603-643-5352 Fax (All departments)
 info@hypertherm.com (Main office email)
 800-643-9878 Tel (Technical service)
 technical.service@hypertherm.com
 (Technical service)
 800-737-2978 Tel (Customer service)
 customer.service@hypertherm.com
 (Customer service)
 866-643-7711 Tel (Return Materials
 Authorization RMA)
 877-371-2876 Fax (RMA)
 return.materials@hypertherm.com (RMA)

Hypertherm México, S.A. de C.V.
 Avenida Toluca No. 444, Anexo 1,
 Colonia Olivar de los Padres
 Delegación Álvaro Obregón
 México, D.F. C.P. 01780
 52 55 5681 8109 Tel
 52 55 5683 2127 Fax
 Soporte.Tecnico@hypertherm.com
 (Technical service)

South America & Central America:
 Hypertherm Brasil Ltda.
 Rua Bras Cubas, 231 - Jardim Maia
 Guarulhos, SP - Brasil
 CEP 07115-030
 55 11 2409 2636 Tel
 tecnico.sa@hypertherm.com (Technical service)

Hypertherm Plasmatechnik GmbH
 Sophie-Scholl-Platz 5
 63452 Hanau
 Germany
 00 800 33 24 97 37 Tel
 00 800 49 73 73 29 Fax
 31 (0) 165 596900 Tel (Technical service)
 00 800 4973 7843 Tel (Technical service)
 technicalservice.emea@hypertherm.com
 (Technical service)

Hypertherm Europe B.V.
 Vaartveld 9, 4704 SE
 Roosendaal, Nederland
 31 165 596907 Tel
 31 165 596901 Fax
 31 165 596908 Tel (Marketing)
 31 (0) 165 596900 Tel (Technical service)
 00 800 4973 7843 Tel (Technical service)
 technicalservice.emea@hypertherm.com
 (Technical service)

Hypertherm (Singapore) Pte Ltd.
 82 Genting Lane
 Media Centre
 Annexe Block #A01-01
 Singapore 349567, Republic of Singapore
 65 6841 2489 Tel
 65 6841 2490 Fax
 Marketing.asia@hypertherm.com (Marketing)
 TechSupportAPAC@hypertherm.com
 (Technical service)

Hypertherm Japan Ltd.
 Level 9, Edobori Center Building
 2-1-1 Edobori, Nishi-ku
 Osaka 550-0002 Japan
 81 6 6225 1183 Tel
 81 6 6225 1184 Fax
 HTJapan.info@hypertherm.com (Main office)
 TechSupportAPAC@hypertherm.com
 (Technical service)

Hypertherm (Shanghai) Trading Co., Ltd.
 B301, 495 ShangZhong Road
 Shanghai, 200231
 PR China
 86-21-80231122 Tel
 86-21-80231120 Fax
 86-21-80231128 Tel (Technical service)
 techsupport.china@hypertherm.com
 (Technical service)

Hypertherm Korea Branch
 #3904, APEC-ro 17, Heundae-gu, Busan.
 Korea 48060
 82 (0)51 747 0358 Tel
 82 (0)51 701 0358 Fax
 Marketing.korea@hypertherm.com (Marketing)
 TechSupportAPAC@hypertherm.com
 (Technical service)

Hypertherm Pty Limited
 GPO Box 4836
 Sydney NSW 2001, Australia
 61 (0) 437 606 995 Tel
 61 7 3219 9010 Fax
 au.sales@Hypertherm.com (Main office)
 TechSupportAPAC@hypertherm.com
 (Technical service)

Hypertherm (India) Thermal Cutting Pvt. Ltd
 A-18 / B-1 Extension,
 Mohan Co-Operative Industrial Estate,
 Mathura Road, New Delhi 110044, India
 91-11-40521201 / 2 / 3 Tel
 91-11 40521204 Fax
 HTIndia.info@hypertherm.com (Main office)
 TechSupportAPAC@hypertherm.com
 (Technical service)

HELPING YOU SHAPE THE WORLD.



PLASMA | LASER | WATERJET | AUTOMATION | SOFTWARE | CONSUMABLES

For more information on Hypertherm consumables,
visit www.hypertherm.com

Hypertherm, Powermax, XPR, HyPerformance, HPR, MAX, LongLife, HySpeed, HSD, HyPro, PAC, HT, HyDefinition, HD, Conical Flow, CoolCore, CoolFlow, HyLife, PowerPierce, QuickLock, TrueFlow, Vented Water Injection, Coaxial-assist, EasyConnect, X-Definition, True Hole, True Bevel, SilverPlus, and Shaping Possibility are trademarks of Hypertherm, Inc. and may be registered in the United States and/or other countries.

Environmental stewardship is one of Hypertherm's core values, and it is critical to our success and our customers' success. We are striving to reduce the environmental impact of everything we do. For more information: www.hypertherm.com/environment.

100% employee owned

© 5/2019 Hypertherm, Inc. Revision 7
880620



Hypertherm[®]
SHAPING POSSIBILITY[®]

